

# DC Motors

Type DMR

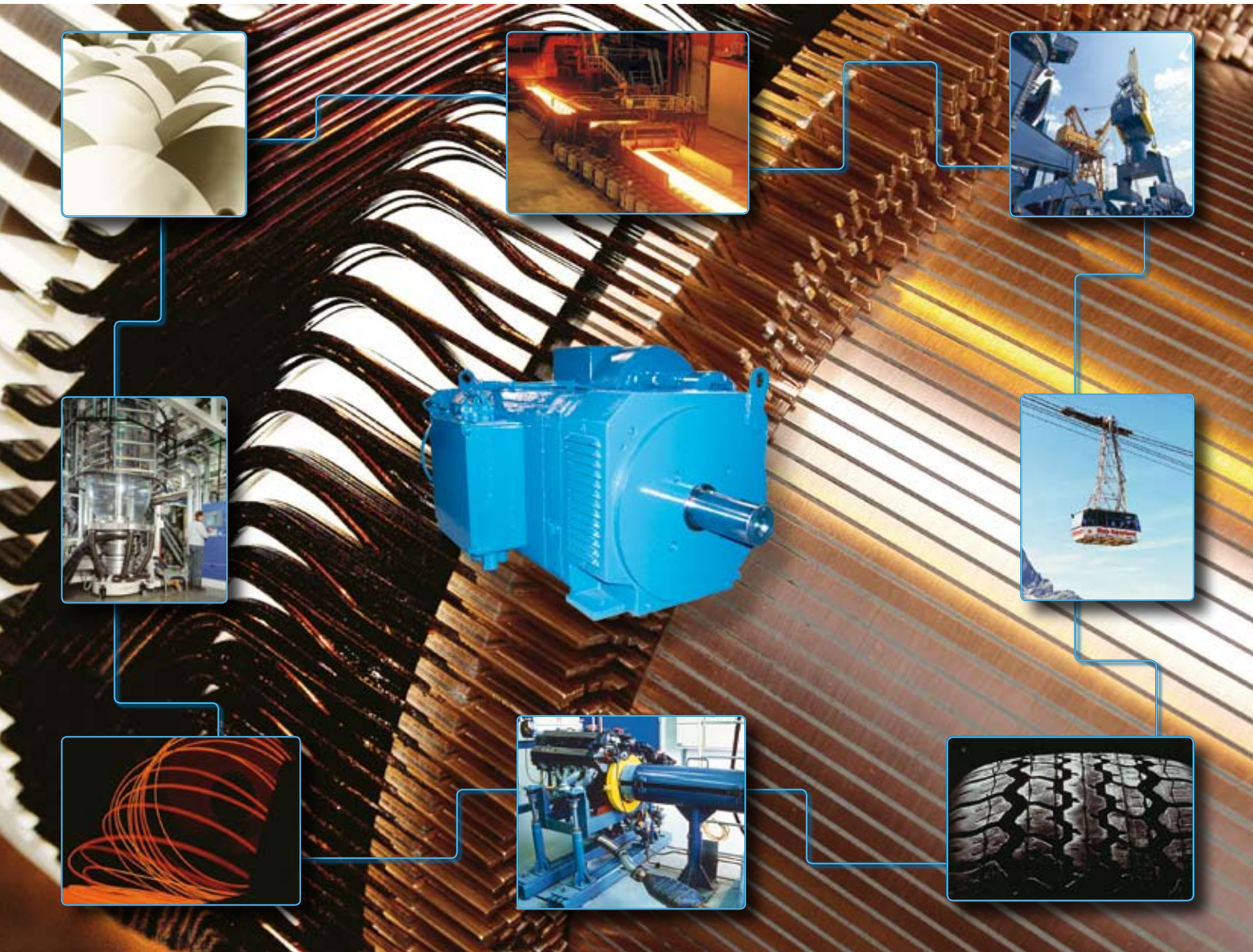



# DC Motors Type DMR

---

## Table of Contents

General	4	Brush monitoring	28
Performance definition	6	Noise level	29
Type selection	8	Vibration severity	29
Preferred types	8	Cooling	30
Type code	10	Brake assignment	31
Technical data	11	Encoder	32
Bearings and shaft loading	24	Structural forms	33
Radial force diagrams	25	Dimensional drawings	34
Connection - terminal designation	28	Operation and Maintenance instructions	41
Temperature monitoring	28		

## General

---

ABB type **DMR** DC motors are manufactured in IEC frame sizes between 112 and 180.

### Structure

The motors are fully laminated and have four poles. They are uncompensated and of class H insulation. On request, the frame size 180 can also be delivered as a compensated motor.

**DMR** DC motors can be designed with mounted radial forced ventilation of IP23 type of protection.

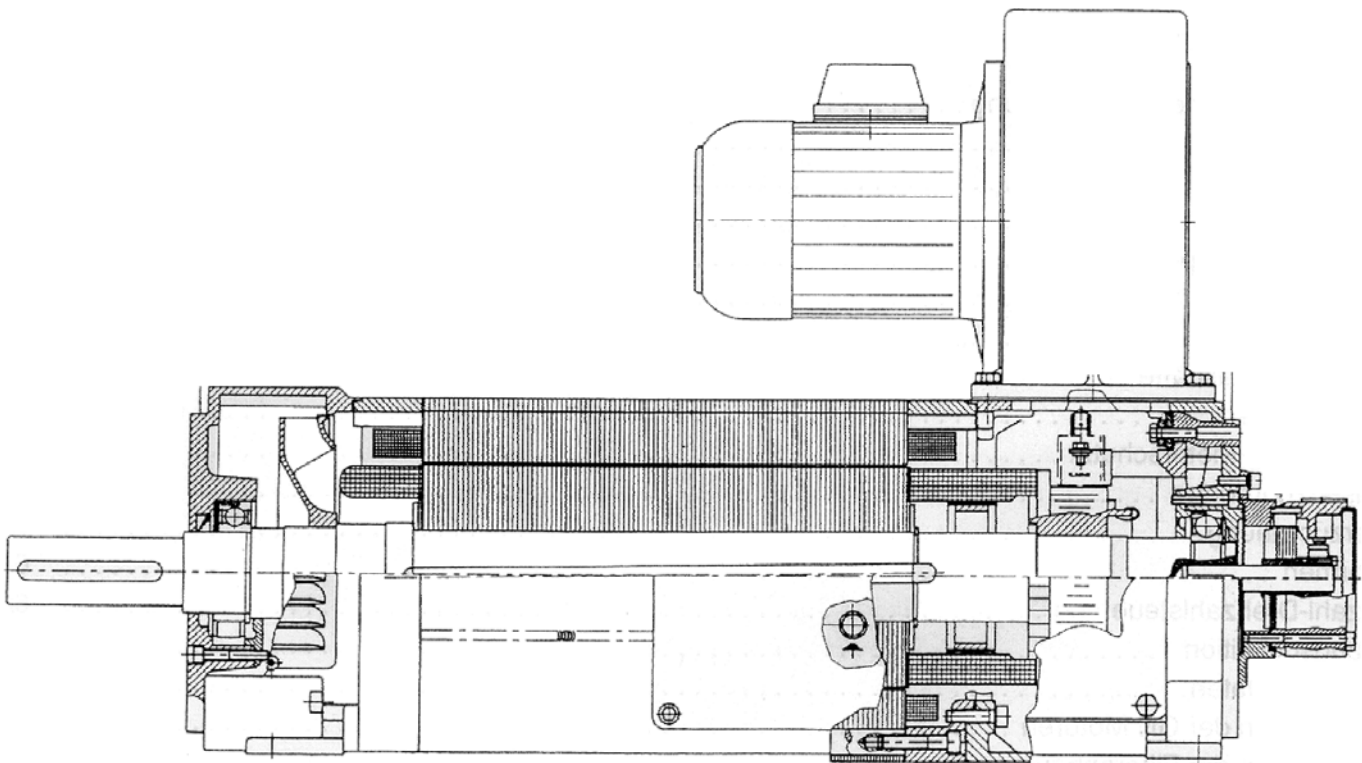

**DMR**

Version EN60034	IM B3	horizontal mounting for size 112-180
	IM B5	horizontal mounting for size 112-160
	IM B35	horizontal mounting for size 112-180
	IM V1	vertical mounting, shaft end to the bottom
	IM V3	vertical mounting, shaft end to the top
Type of protection	IP23	internally cooled, with fan (IP20 for version V) EN60034-5
Connection	Main connection	Terminal box
	Control connection	Tachometer conn. (option pulse encoder, 12-pin connector)
	Brake	inside terminal box
	Thermal sensor	inside terminal box
Type of cooling	IC 06/17/37	internally cooled machine with fan
Thermal sensor		2 thermal relays
Temperature rise	$\Delta\vartheta = 125\text{ K}$	insulation class H acc. to EN 60034
Temperature range	0...+ 40° C,	
Storage	-30° C...+85° C	
Paint		Munsell 8B 4.5/3.25
Bearings	$\geq 20,000\text{ h}$	Service life
Balance quality	N	acc. to DIN EN 60034 -14
	R, S	On request
Vibration-resistant up to	3g	Higher vibration-resistance on request
Flange	acc. to IEC standard 42948.	Axial or radial tolerance acc. to DIN 42955N option R
Shaft end	cylindrical	acc. to DIN 748 with keyway DIN 6885; centring with internal thread
		acc. to DIN 332 form D (also available without keyway); Dim. d:Tolerance (without keyway h6)
Holding brake	Optional	
Actual speed encoder	DC Tacho	Incremental encoder (optional)
		Other encoders on request

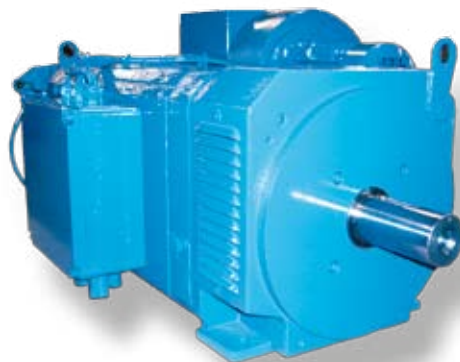



## Performance Definition

---

### Performance Definition

The power output stated in the list applies to continuous running duty (S1) at nominal speed, at a maximum ambient temperature of 40° C and at a site altitude of less than 1000 m above sea level. The armature circuit is fed with direct current whose harmonic content does not exceed 25%.

The motor must be operated close to the nominal working point. Running the motor for a relatively long period of time and reaching less than 60% of the nominal power results in underload operation. In this case ask ABB to take special measures for this, otherwise the full warranty cannot be granted.

If motors are to be operated at an ambient temperature of more than 40° C or at site altitudes of more than 1000 m above sea level, the required list power PL is the product of factors k1 or k2 and the required power P.

Ambient temperature	40°C	45°C	50°C	55°C	60°C
Correction factor k <sub>1</sub> approximately	1	1.06	1.13	1.22	1.34
Altitude above sea level up to	1000m	2000m	3000m	4000m	5000m
Correction factor k <sub>2</sub> approximately.	1	1.07	1.16	1.27	1.55

At ambient temperatures above 40° C and with motors of enclosed design, contact the manufacturer for any design modifications that may be required

In the case of sites above 1000 m where the ambient temperature drops by approx. 10° C per 1000 m, power correction is not necessary.

### Operating Modes

Please inquire at the factory about motors for intermediate periodic loading (S 3), continuous duty with intermittent loading (S 6), short-time duty (S 2) and about motors for switching operation (S 4, S 5, S 7). If necessary, please quote operating and break times, torques, transformation ratios etc. inquire at the factory. You can roughly calculate as shown below the necessary list power, P<sub>L</sub> from the product of k<sub>4</sub> and the required power output P for operating modes S 2, S 3 and S 6:

Intermediate periodic loading S 3 with ED	15%	25%	40%	60%
With internally cooled machines	0.6	0.7	0.8	0.9
Continuous duty with intermittent loading S 6 with ED	15%	25%	40%	60%
With internally cooled machines factor k <sub>4</sub>	0.6	0.6	0.65	0.8
Short-time duty S 2 with ED	10 min	30 min	60 min	90 min
With internally cooled machines factor k <sub>4</sub>	0.6	0.73	0.9	0.96

### Winding Insulation and Heating

All the machines of this series are designed to comply with insulation material class H according to EN 60034 for a permissible winding overtemperature of 125 K at an ambient temperature of up to 40° C. The insulation is resistant to the gases and vapours of flammable materials and meets the requirements that are made of materials that are damp-resistant and suitable for tropical conditions.

Special insulation is available at an extra charge, which is necessary in conditions in which there is concentrated acid vapour or metal dust or where the relative humidity is permanently above 80%. The insulation is also needed to provide protection from termites and mould.

When placing your order, you must state the following operating and ambient conditions:

- Light load less than 60% of nominal load, for a relatively long period
- Temperature of cooling air less than 10° C
- Relative humidity less than 10% or greater than 80%
- If gases and vapours occur, such as chlorine, hydrogen sulphide, silicone or oil, for example, you must state the type and concentration.

### Overload capacity

In accordance with EN 60034, the motors have a 1.5-fold current overload capacity for 45 seconds at the rated voltage and the rated excitation (note the reduced values with field weakening operation).

Motors for higher or longer peak loads or reduced motor moments of inertia are available on request.

### Controlled speed reduction

You reduce the RPM speed by reducing the armature voltage.

The DC motors in this catalogue have a constant torque of up to 50 RPM downwards in the armature control range.

### Controlled speed increase

Increasing the RPM speed is carried out by means of field weakening without losses starting from the basic RPM speed. In this connection, you can retain the list power for the basic RPM speed across the field weakening range assuming that the increase in the RPM speed does not exceed the value  $n_{\max \text{ elektrisch}}$ , which is stated in the list.

In the case of short-time duty or intermediate periodic loading, it is permissible to increase the power above the list power.

In field weakening operation, there is a limited overload capacity.

Field weakening above  $n_{\max \text{ electrical}}$  is possible in many cases; however, it always results in a reduction in power.

In the case of extreme field control ranges, you must provide a compensating winding to limit the armature reaction.

### Excitation

The exciter power losses in the list refer to separately excited machines without a stabilizing series winding.

In the case of switch off on the DC side, a free-wheeling diode or a parallel resistor must protect the field winding from closing overvoltages.

By preference, you should use the standard voltage of 310 V as the field voltage. In this case too it is possible to use different voltages; in particular, the 340 V output voltage that can be obtained from the bridge circuit with a 400-V feed.

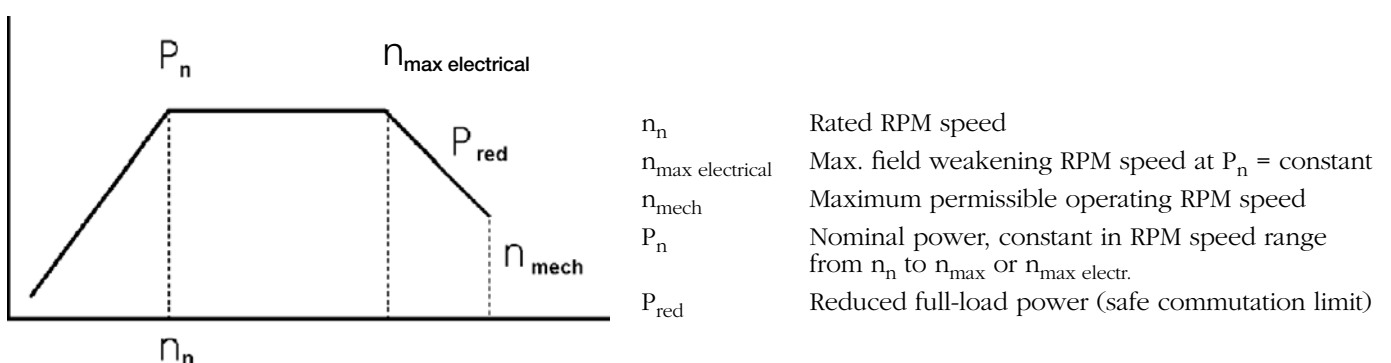

## Performance Definition

---

## Type Selection

---

## Preferred Types

---

### Stabilizing series winding

A stabilizing series winding can be fitted on request to stabilize the RPM speed.

All motors that are intended for tachometer control, as well as compensated motors are executed without a stabilizing series winding.

### Compensating winding

For special requirements, e.g. impulse load operation, reversing operation and with a large field weakening range, it is possible to execute the frame size 180 with a compensating winding.

Changes in RPM speed and output with a compensating winding:

Reduction factor			
Size	Speed	Torque	Output
180	0.94	0.93	0.874

## Type Selection

Converting list values to the desired RPM speed:

Normally, you start from the next highest RPM speed. You set the desired – lower – RPM speed by reducing the armature voltage on the armature voltage regulator. The torque remains constant with the output reducing with the RPM speed.

Starting from the next lowest RPM speed, you can set the desired – higher – RPM speed at constant output by field weakening (reducing the exciter current). This is an option with the field supply.

## Preferred Types

The motor types that are shown in the technical data with a grey background are preferred types.

The technical design of the preferred types is as follows:

- Fan at top, on B side, fan screw to right
- Rectangular filter to B side
- KLK on right, on B side, PGs according to dimensional drawing
- Tachometer generator GHT S 42 with 20V/1000 RPM
- Structural form IM B3
- Type of protection IP 23
- Ball bearings
- 2 thermal protectors (one in commutating pole and one in field for switch off)
- Insulation material class H
- Exciter voltage 310 V
- Paintwork Munsell 8B 4.5/3.25

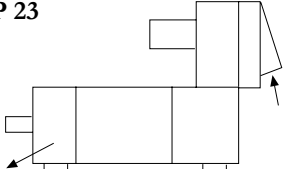
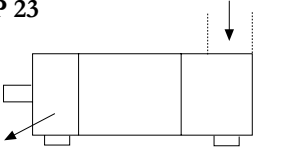
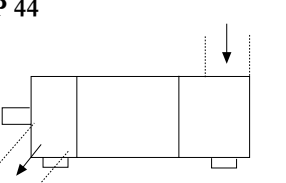

IP	Methods of cooling	Modes de refroidissement	Kühlarten
<p><b>IP 23</b></p> 	<p><b>IC 06</b> Motor-mounted fan and free circulation</p>	<p><b>IC 06</b> Ventilateur monté sur moteur et circulation libre</p>	<p><b>IC 06</b> Durchzugbelüftung durch aufgebauten Fremdlüfter</p>
<p><b>IP 23</b></p> 	<p><b>IC 17</b> Ducted air supply and free circulation</p>	<p><b>IC 17</b> Conduits d'alimentation d'air et circulation libre</p>	<p><b>IC 17</b> Durchzugbelüftung mit getrenntem Kühlluft-eintritt</p>
<p><b>IP 44</b></p> 	<p><b>IC 37</b> Ducted air supply and exhaust</p>	<p><b>IC 37</b> Conduits d'alimentation et d'évacuation d'air</p>	<p><b>IC 37</b> Getrennter Kühlluft-eintritt und -austritt</p>

At the top  
Sur le dessus  
Oben

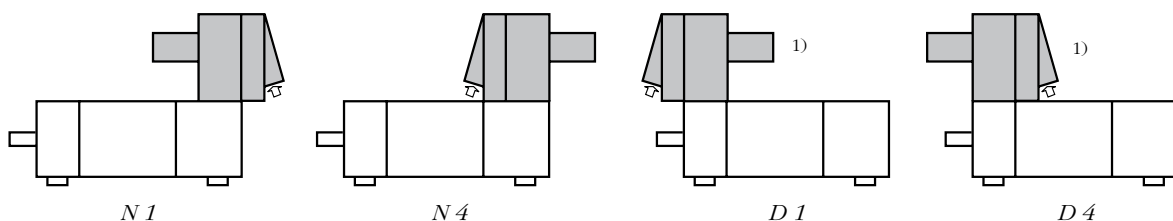

On right side  
Sur le côté droit  
Rechts

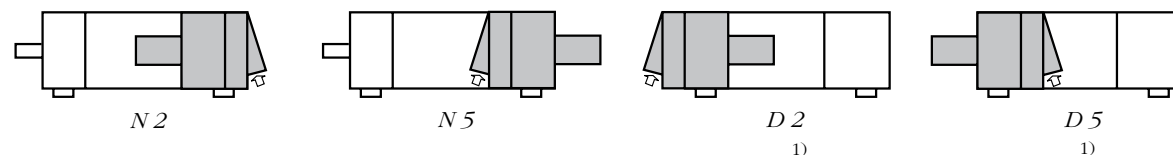

On left side  
Sur le côté gauche  
Links

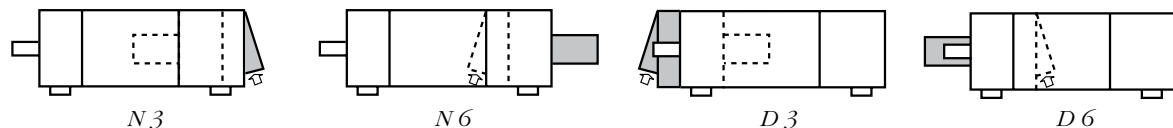

<sup>1)</sup> Motor size will perhaps be affected.



**DMR 112 SN**

400 [V]	Speed n Armature voltage Ua of:				Out- put [kW]	Out- put [hp]	n max electr. [min-1]	Armature current [A]	Torque [Nm]	Torque [lbf ft]	Effectivity		Induc- tivity [mH]	Armature circuit impedance [Ohm]	Order DesiDMRtion
	420 [V]	460 [V]	480 [V]	eta A [%]							eta tot [%]				
<b>3100</b>				<b>22,0</b>	<b>30</b>	4500	62	67,8	50	89,3	87,3	5,20	0,32	DMR 112 SN- 472O	
	<b>3270</b>			<b>23,2</b>	<b>31</b>	4500	62	67,8	50	89,6	87,7	5,20	0,32	DMR 112 SN- 472P	
		<b>3610</b>		<b>25,6</b>	<b>34</b>	4500	62	67,8	50	90,3	88,5	5,20	0,32	DMR 112 SN- 472R	
			<b>3770</b>	<b>26,8</b>	<b>36</b>	4500	62	67,8	50	90,5	88,8	5,20	0,32	DMR 112 SN- 472T	
<b>2620</b>				<b>18,5</b>	<b>25</b>	3900	52	67,4	50	88,3	86,0	7,10	0,43	DMR 112 SN- 47CO	
	<b>2760</b>			<b>19,5</b>	<b>26</b>	3900	52	67,4	50	88,7	86,5	7,10	0,43	DMR 112 SN- 47CP	
		<b>3050</b>		<b>21,5</b>	<b>29</b>	3900	52	67,4	50	89,4	87,4	7,10	0,43	DMR 112 SN- 47CR	
			<b>3200</b>	<b>22,6</b>	<b>30</b>	3900	52	67,4	50	89,7	87,8	7,10	0,43	DMR 112 SN- 47CT	
<b>2250</b>				<b>15,9</b>	<b>21</b>	2900	46	67,5	50	86,6	84,0	9,20	0,58	DMR 112 SN- 47DO	
	<b>2380</b>			<b>16,8</b>	<b>23</b>	2900	46	67,5	50	87,1	84,7	9,20	0,58	DMR 112 SN- 47DP	
		<b>2630</b>		<b>18,6</b>	<b>25</b>	2900	46	67,5	50	88,0	85,7	9,20	0,58	DMR 112 SN- 47DR	
			<b>2750</b>	<b>19,4</b>	<b>26</b>	2900	46	67,5	50	88,3	86,1	9,20	0,58	DMR 112 SN- 47DT	
<b>1970</b>				<b>13,9</b>	<b>19</b>	2900	41	67,4	50	85,6	82,7	11,70	0,75	DMR 112 SN- 473O	
	<b>2080</b>			<b>14,7</b>	<b>20</b>	2900	41	67,4	50	86,1	83,4	11,70	0,75	DMR 112 SN- 473P	
		<b>2310</b>		<b>16,3</b>	<b>22</b>	2900	41	67,4	50	87,1	84,6	11,70	0,75	DMR 112 SN- 473R	
			<b>2420</b>	<b>17,1</b>	<b>23</b>	2900	41	67,4	50	87,5	85,1	11,70	0,75	DMR 112 SN- 473T	
<b>1420</b>				<b>10,2</b>	<b>14</b>	2600	31	68,6	51	82,5	78,9	20,70	1,32	DMR 112 SN- 474O	
	<b>1500</b>			<b>10,8</b>	<b>14</b>	2600	31	68,6	51	83,2	79,8	20,70	1,32	DMR 112 SN- 474P	
		<b>1670</b>		<b>12,0</b>	<b>16</b>	2600	31	68,6	51	84,5	81,2	20,70	1,32	DMR 112 SN- 474R	
			<b>1760</b>	<b>12,6</b>	<b>17</b>	2600	31	68,6	51	85,0	81,9	20,70	1,32	DMR 112 SN- 474T	
<b>1090</b>				<b>7,8</b>	<b>10</b>	2000	25	68,3	50	79,3	75,0	32,20	2,03	DMR 112 SN- 475O	
	<b>1160</b>			<b>8,3</b>	<b>11</b>	2000	25	68,3	50	80,2	76,1	32,20	2,03	DMR 112 SN- 475P	
		<b>1290</b>		<b>9,2</b>	<b>12</b>	2000	25	68,3	50	81,6	77,8	32,20	2,03	DMR 112 SN- 475R	
			<b>1360</b>	<b>9,7</b>	<b>13</b>	2000	25	68,3	50	82,3	78,6	32,20	2,03	DMR 112 SN- 475T	

Form Factor	< 1.03	Excitation Power	560 W	Operating Mode	S 1	Weight	100 kg
Mech. limit speed	6700 RPM	Excitation current at 310V	1.8 A	Type of protection	IP 23	Uncompensated	
Moment of inertia	0.05 kgm <sup>2</sup>	Insulation material class	H	Type of cooling	IC 06/17/37		

## Technical Data

### DMR 112 MN

400	Speed n Armature voltage Ua of:			Out- put	Out- put	n max electr.	Armature current	Torque	Torque	Effectivity		Induc- tivity	Armature circuit impedance	Order DesiDMRtion
	420	460	480							eta A	eta tot			
[V]	[V]	[V]	[V]	Pab	Pab		Ia	M	M	[%]	[%]	La	Ra	
				[kW]	[hp]	[min-1]	[A]	[Nm]	[lbf ft]	[%]	[%]	[mH]	[Ohm]	
<b>2970</b>				<b>23,9</b>	<b>32</b>	4300	67	76,9	57	88,9	86,9	4,50	0,25	DMR 112 MN- 47BO
	<b>3130</b>			<b>25,2</b>	<b>34</b>	4300	67	76,9	57	89,3	87,3	4,50	0,25	DMR 112 MN- 47BP
		<b>3450</b>		<b>27,8</b>	<b>37</b>	4300	67	76,9	57	89,9	88,1	4,50	0,25	DMR 112 MN- 47BR
			<b>3610</b>	<b>29,1</b>	<b>39</b>	4300	67	76,9	57	90,2	88,5	4,50	0,25	DMR 112 MN- 47BT
<b>2430</b>				<b>20,0</b>	<b>27</b>	4200	57	78,6	58	87,6	85,2	6,60	0,40	DMR 112 MN- 472O
	<b>2560</b>			<b>21,1</b>	<b>28</b>	4200	57	78,6	58	88,0	85,7	6,60	0,40	DMR 112 MN- 472P
		<b>2830</b>		<b>23,3</b>	<b>31</b>	4200	57	78,6	58	88,8	86,7	6,60	0,40	DMR 112 MN- 472R
			<b>2970</b>	<b>24,5</b>	<b>33</b>	4200	57	78,6	58	89,1	87,1	6,60	0,40	DMR 112 MN- 472T
<b>2050</b>				<b>17,5</b>	<b>23</b>	3600	50	81,5	60	87,1	84,4	9,00	0,52	DMR 112 MN- 47CO
	<b>2160</b>			<b>18,4</b>	<b>25</b>	3600	50	81,5	60	87,5	85,0	9,00	0,52	DMR 112 MN- 47CP
		<b>2390</b>		<b>20,4</b>	<b>27</b>	3600	50	81,5	60	88,4	86,0	9,00	0,52	DMR 112 MN- 47CR
			<b>2510</b>	<b>21,4</b>	<b>29</b>	3600	50	81,5	60	88,8	86,5	9,00	0,52	DMR 112 MN- 47CT
<b>1550</b>				<b>13,2</b>	<b>18</b>	3000	39	81,3	60	84,2	80,9	14,80	0,86	DMR 112 MN- 473O
	<b>1640</b>			<b>14,0</b>	<b>19</b>	3000	39	81,3	60	84,8	81,7	14,80	0,86	DMR 112 MN- 473P
		<b>1820</b>		<b>15,5</b>	<b>21</b>	3000	39	81,3	60	85,9	83,0	14,80	0,86	DMR 112 MN- 473R
			<b>1910</b>	<b>16,3</b>	<b>22</b>	3000	39	81,3	60	86,4	83,6	14,80	0,86	DMR 112 MN- 473T

Form Factor	< 1.03	Excitation Power	650 W	Operating Mode	S 1	Weight	122 kg
Mech. limit speed	6700 RPM	Excitation current at 310V	2.1 A	Type of protection	IP 23	Uncompensated	
Moment of inertia	0.06 kgm <sup>2</sup>	Insulation material class	H	Type of cooling	IC 06/17/37		

**DMR 112 LN**

400	Speed n Armature voltage Ua of:			Out- put Pab	Out- put Pab	n max electr.	Armature current Ia	Torque M	Torque M	Effectivity		Induc- tivity La	Armature circuit impedance Ra	Order DesiDMRtion
	420	460	480							eta A	eta tot			
[V]	[V]	[V]	[V]	[kW]	[hp]	[min-1]	[A]	[Nm]	[lbf ft]	[%]	[%]	[mH]	[Ohm]	
<b>3040</b>				<b>28,0</b>	<b>38</b>	4800	79	87,9	65	88,7	86,7	3,70	0,21	DMR 112 LN- 47AO
	<b>3200</b>			<b>29,5</b>	<b>40</b>	4800	79	87,9	65	89,0	87,2	3,70	0,21	DMR 112 LN- 47AP
		<b>3530</b>		<b>32,5</b>	<b>44</b>	4800	79	87,9	65	89,7	88,0	3,70	0,21	DMR 112 LN- 47AR
			<b>3690</b>	<b>34,0</b>	<b>46</b>	4800	79	87,9	65	90,0	88,3	3,70	0,21	DMR 112 LN- 47AT
<b>2400</b>				<b>23,5</b>	<b>32</b>	4200	66	93,5	69	88,4	86,1	5,70	0,29	DMR 112 LN- 47BO
	<b>2530</b>			<b>24,8</b>	<b>33</b>	4200	66	93,5	69	88,8	86,7	5,70	0,29	DMR 112 LN- 47BP
		<b>2790</b>		<b>27,3</b>	<b>37</b>	4200	66	93,5	69	89,5	87,5	5,70	0,29	DMR 112 LN- 47BR
			<b>2920</b>	<b>28,6</b>	<b>38</b>	4200	66	93,5	69	89,9	87,9	5,70	0,29	DMR 112 LN- 47BT
<b>1950</b>				<b>19,3</b>	<b>26</b>	3800	56	94,5	70	86,4	83,8	8,20	0,46	DMR 112 LN- 472O
	<b>2060</b>			<b>20,4</b>	<b>27</b>	3800	56	94,5	70	86,9	84,4	8,20	0,46	DMR 112 LN- 472P
		<b>2280</b>		<b>22,6</b>	<b>30</b>	3800	56	94,5	70	87,8	85,5	8,20	0,46	DMR 112 LN- 472R
			<b>2390</b>	<b>23,7</b>	<b>32</b>	3800	56	94,5	70	88,2	86,0	8,20	0,46	DMR 112 LN- 472T
<b>1240</b>				<b>12,4</b>	<b>17</b>	2600	37	95,5	70	83,0	79,3	18,60	1,00	DMR 112 LN- 473O
	<b>1310</b>			<b>13,1</b>	<b>18</b>	2600	37	95,5	70	83,7	80,1	18,60	1,00	DMR 112 LN- 473P
		<b>1460</b>		<b>14,6</b>	<b>20</b>	2600	37	95,5	70	84,9	81,6	18,60	1,00	DMR 112 LN- 473R
			<b>1530</b>	<b>15,3</b>	<b>21</b>	2600	37	95,5	70	85,4	82,2	18,60	1,00	DMR 112 LN- 473T

Form Factor	< 1.03	Excitation Power	700 W	Operating Mode	S 1	Weight	152 kg
Mech. limit speed	5300 RPM	Excitation current at 310V	2.3 A	Type of protection	IP 23	Uncompensated	
Moment of inertia	0.08 kgm <sup>2</sup>	Insulation material class	H	Type of cooling	IC 06/17/37		

## Technical Data

### DMR 132 KN

400	Speed n Armature voltage Ua of:			Out- put	Out- put	n max electr.	Armature current	Torque	Torque	Effectivity		Induc- tivity	Armature circuit impedance	Order DesiDMRtion
	420	460	480							eta A	eta tot			
[V]	[V]	[V]	[V]	Pab	Pab	[min-1]	Ia	M	M	[%]	[%]	La	Ra	
				[kW]	[hp]		[A]	[Nm]	[lbf ft]			[mH]	[Ohm]	
<b>2950</b>				<b>23,0</b>	<b>31</b>	4500	67	74,5	55	86,5	83,8	5,20	0,30	DMR 132 KN- 272O
	<b>3110</b>			<b>24,3</b>	<b>33</b>	4500	66	74,5	55	86,9	84,3	5,20	0,30	DMR 132 KN- 272P
		<b>3440</b>		<b>26,8</b>	<b>36</b>	4500	66	74,5	55	87,7	85,3	5,20	0,30	DMR 132 KN- 272R
			<b>3600</b>	<b>28,1</b>	<b>38</b>	4500	66	74,5	55	88,1	85,7	5,20	0,30	DMR 132 KN- 272T
<b>2500</b>				<b>20,5</b>	<b>27</b>	4000	59	78,3	58	86,9	83,8	7,10	0,39	DMR 132 KN- 27CO
	<b>2640</b>			<b>21,6</b>	<b>29</b>	4000	59	78,3	58	87,3	84,4	7,10	0,39	DMR 132 KN- 27CP
		<b>2920</b>		<b>23,9</b>	<b>32</b>	4000	59	78,3	58	88,2	85,4	7,10	0,39	DMR 132 KN- 27CR
			<b>3050</b>	<b>25,0</b>	<b>34</b>	4000	59	78,3	58	88,5	85,9	7,10	0,39	DMR 132 KN- 27CT
<b>2110</b>				<b>18,2</b>	<b>24</b>	3600	53	82,3	61	85,8	82,4	9,50	0,53	DMR 132 KN- 473O
	<b>2230</b>			<b>19,2</b>	<b>26</b>	3600	53	82,3	61	86,3	83,1	9,50	0,53	DMR 132 KN- 473P
		<b>2470</b>		<b>21,3</b>	<b>29</b>	3600	53	82,3	61	87,2	84,3	9,50	0,53	DMR 132 KN- 473R
			<b>2590</b>	<b>22,3</b>	<b>30</b>	3600	53	82,3	61	87,6	84,8	9,50	0,53	DMR 132 KN- 473T
<b>1520</b>				<b>13,5</b>	<b>18</b>	2900	41	84,8	63	82,7	78,6	16,60	0,90	DMR 132 KN- 474O
	<b>1610</b>			<b>14,3</b>	<b>19</b>	2900	41	84,8	63	83,4	79,4	16,60	0,90	DMR 132 KN- 474P
		<b>1790</b>		<b>15,9</b>	<b>21</b>	2900	41	84,8	63	84,6	80,9	16,60	0,90	DMR 132 KN- 474R
			<b>1880</b>	<b>16,7</b>	<b>22</b>	2900	41	84,8	63	85,1	81,6	16,60	0,90	DMR 132 KN- 474T
<b>1160</b>				<b>10,3</b>	<b>14</b>	2100	33	84,8	63	78,3	73,5	25,90	1,45	DMR 132 KN- 475O
	<b>1230</b>			<b>10,9</b>	<b>15</b>	2100	33	84,8	63	79,2	74,5	25,90	1,45	DMR 132 KN- 475P
		<b>1370</b>		<b>12,2</b>	<b>16</b>	2100	33	84,8	63	80,7	76,3	25,90	1,45	DMR 132 KN- 475R
			<b>1450</b>	<b>12,9</b>	<b>17</b>	2100	33	84,8	63	81,4	77,2	25,90	1,45	DMR 132 KN- 475T

Form Factor	< 1.03	Excitation Power	750 W	Operating Mode	S 1	Weight 125 kg Uncompensated
Mech. limit speed	5300 RPM	Excitation current at 310V	2.4 A	Type of protection	IP 23	
Moment of inertia	0.07 kgm <sup>2</sup>	Insulation material class	H	Type of cooling	IC 06/17/37	



**DMR 132 SN**

400	Speed n Armature voltage Ua of:				Out- put	Out- put	n max electr.	Armature current	Torque	Torque	Effectivity		Induc- tivity	Armature circuit impedance	Order DesiDMRtion
	420	460	480	Pab							Pab	la			
[V]	[V]	[V]	[V]	[kW]	[hp]	[min-1]	[A]	[Nm]	[lbf ft]	[%]	[%]	[mH]	[Ohm]		
<b>2910</b>				<b>34,5</b>	<b>46</b>	4500	97	113	83	88,8	86,6	3,90	0,19	DMR 132 SN-	47BO
	<b>3070</b>			<b>36,4</b>	<b>49</b>	4500	97	113	83	89,2	87,1	3,90	0,19	DMR 132 SN-	47BP
		<b>3380</b>		<b>40,1</b>	<b>54</b>	4500	97	113	83	89,9	87,9	3,90	0,19	DMR 132 SN-	47BR
			<b>3540</b>	<b>42,0</b>	<b>56</b>	4500	97	113	83	90,1	88,3	3,90	0,19	DMR 132 SN-	47BT
<b>2390</b>				<b>29,0</b>	<b>39</b>	4000	82	116	86	88,1	85,5	5,70	0,28	DMR 132 SN-	472O
	<b>2520</b>			<b>30,6</b>	<b>41</b>	4000	82	116	86	88,5	86,0	5,70	0,28	DMR 132 SN-	472P
		<b>2790</b>		<b>33,8</b>	<b>45</b>	4000	82	116	86	89,3	87,0	5,70	0,28	DMR 132 SN-	472R
			<b>2920</b>	<b>35,4</b>	<b>47</b>	4000	82	116	86	89,6	87,4	5,70	0,28	DMR 132 SN-	472T
<b>2130</b>				<b>26,5</b>	<b>36</b>	3600	76	119	88	87,2	84,4	7,00	0,34	DMR 132 SN-	272O
	<b>2250</b>			<b>28,0</b>	<b>38</b>	3600	76	119	88	87,7	85,0	7,00	0,34	DMR 132 SN-	272P
		<b>2490</b>		<b>31,0</b>	<b>42</b>	3600	76	119	88	88,5	86,0	7,00	0,34	DMR 132 SN-	272R
			<b>2600</b>	<b>32,3</b>	<b>43</b>	3600	76	119	88	88,8	86,5	7,00	0,34	DMR 132 SN-	272T
<b>1520</b>				<b>19,0</b>	<b>25</b>	2900	56	119	88	85,0	81,3	12,80	0,63	DMR 132 SN-	473O
	<b>1610</b>			<b>20,1</b>	<b>27</b>	2900	56	119	88	85,6	82,1	12,80	0,63	DMR 132 SN-	473P
		<b>1780</b>		<b>22,3</b>	<b>30</b>	2900	56	119	88	86,6	83,4	12,80	0,63	DMR 132 SN-	473R
			<b>1870</b>	<b>23,4</b>	<b>31</b>	2900	56	119	88	87,1	84,0	12,80	0,63	DMR 132 SN-	473T
<b>1090</b>				<b>13,8</b>	<b>19</b>	2100	42	121	89	81,4	76,8	22,50	1,06	DMR 132 SN-	474O
	<b>1160</b>			<b>14,7</b>	<b>20</b>	2100	42	121	89	82,2	77,8	22,50	1,06	DMR 132 SN-	474P
		<b>1290</b>		<b>16,3</b>	<b>22</b>	2100	42	121	89	83,5	79,5	22,50	1,06	DMR 132 SN-	474R
			<b>1350</b>	<b>17,1</b>	<b>23</b>	2100	42	121	89	84,1	80,2	22,50	1,06	DMR 132 SN-	474T

Form Factor	< 1.03	Excitation Power	1000 W	Operating Mode	S 1	Weight	160 kg
Mech. limit speed	5300 RPM	Excitation current at 310V	3.2 A	Type of protection	IP 23	Uncompensated	
Moment of inertia	0.09 kgm <sup>2</sup>	Insulation material class	H	Type of cooling	IC 06/17/37		

## Technical Data

### DMR 132 MN

400	Speed n Armature voltage Ua of:				Out- put	Out- put	n max electr.	Armature current	Torque	Torque	Effectivity		Induc- tivity	Armature circuit impedance	Order DesiDMRtion
	420	460	480	Pab							Pab	Ia			
[V]	[V]	[V]	[V]	[kW]	[hp]	[min-1]	[A]	[Nm]	[lbf ft]	[%]	[%]	[mH]	[Ohm]		
<b>3170</b>				<b>50,0</b>	<b>67</b>	4500	139	151	111	89,9	88,0	2,50	0,11	DMR 132 MN- 271O	
	<b>3340</b>			<b>52,7</b>	<b>71</b>	4500	139	151	111	90,3	88,4	2,50	0,11	DMR 132 MN- 271P	
		<b>3680</b>		<b>58,0</b>	<b>78</b>	4500	139	151	111	90,8	89,2	2,50	0,11	DMR 132 MN- 271R	
			<b>3850</b>	<b>60,7</b>	<b>81</b>	4500	139	151	111	91,1	89,5	2,50	0,11	DMR 132 MN- 271T	
<b>2600</b>				<b>42,5</b>	<b>57</b>	4300	119	156	115	89,5	87,3	3,60	0,16	DMR 132 MN- 47AO	
	<b>2740</b>			<b>44,8</b>	<b>60</b>	4300	119	156	115	89,8	87,7	3,60	0,16	DMR 132 MN- 47AP	
		<b>3020</b>		<b>49,4</b>	<b>66</b>	4300	119	156	115	90,5	88,5	3,60	0,16	DMR 132 MN- 47AR	
			<b>3160</b>	<b>51,6</b>	<b>69</b>	4300	119	156	115	90,8	88,9	3,60	0,16	DMR 132 MN- 47AT	
<b>2040</b>				<b>35,0</b>	<b>47</b>	3400	99	164	121	88,0	85,5	5,60	0,24	DMR 132 MN- 47BO	
	<b>2150</b>			<b>36,9</b>	<b>49</b>	3400	99	164	121	88,5	86,0	5,60	0,24	DMR 132 MN- 47BP	
		<b>2380</b>		<b>40,8</b>	<b>55</b>	3400	99	164	121	89,3	87,0	5,60	0,24	DMR 132 MN- 47BR	
			<b>2490</b>	<b>42,7</b>	<b>57</b>	3400	99	164	121	89,6	87,4	5,60	0,24	DMR 132 MN- 47BT	
<b>1490</b>				<b>26,0</b>	<b>35</b>	2800	76	167	123	86,1	82,8	9,90	0,44	DMR 132 MN- 272O	
	<b>1580</b>			<b>27,6</b>	<b>37</b>	2800	76	167	123	86,7	83,5	9,90	0,44	DMR 132 MN- 272P	
		<b>1750</b>		<b>30,5</b>	<b>41</b>	2800	76	167	123	87,7	84,7	9,90	0,44	DMR 132 MN- 272R	
			<b>1830</b>	<b>31,9</b>	<b>43</b>	2800	76	167	123	88,1	85,2	9,90	0,44	DMR 132 MN- 272T	
<b>1050</b>				<b>18,0</b>	<b>24</b>	1900	55	164	121	82,1	77,9	18,00	0,75	DMR 132 MN- 473O	
	<b>1110</b>			<b>19,0</b>	<b>25</b>	1900	55	164	121	82,8	78,7	18,00	0,75	DMR 132 MN- 473P	
		<b>1240</b>		<b>21,3</b>	<b>29</b>	1900	55	164	121	84,2	80,4	18,00	0,75	DMR 132 MN- 473R	
			<b>1300</b>	<b>22,3</b>	<b>30</b>	1900	55	164	121	84,8	81,1	18,00	0,75	DMR 132 MN- 473T	

Form Factor	< 1.03	Excitation Power	1200 W	Operating Mode	S 1	Weight	185 kg
Mech. limit speed	5300 RPM	Excitation current at 310V	3.9 A	Type of protection	IP 23	Uncompensated	
Moment of inertia	0.12 kgm <sup>2</sup>	Insulation material class	H	Type of cooling	IC 06/17/37		

**DMR 132 LN**

400	Speed n Armature voltage Ua of:			Out- put	Out- put	n max electr.	Armature current	Torque	Torque	Effectivity		Induc- tivity	Armature circuit impedance	Order DesiDMRtion
	420	460	480							eta A	eta tot			
[V]	[V]	[V]	[V]	[kW]	[hp]	[min-1]	[A]	[Nm]	[lbf ft]	[%]	[%]	[mH]	[Ohm]	
<b>2660</b>				<b>51,0</b>	<b>68</b>	4000	143	183	135	89,2	87,1	2,70	0,11	DMR 132 LN- 471O
	<b>2800</b>			<b>53,7</b>	<b>72</b>	4000	143	183	135	89,6	87,5	2,70	0,11	DMR 132 LN- 471P
		<b>3090</b>		<b>59,3</b>	<b>80</b>	4000	143	183	135	90,2	88,3	2,70	0,11	DMR 132 LN- 471R
			<b>3230</b>	<b>61,9</b>	<b>82</b>	4000	143	183	135	90,5	88,7	2,70	0,11	DMR 132 LN- 471T
<b>1950</b>				<b>40,0</b>	<b>54</b>	3500	114	196	145	88,0	85,4	4,80	0,19	DMR 132 LN- 47AO
	<b>2060</b>			<b>42,3</b>	<b>57</b>	3500	114	196	145	88,5	85,9	4,80	0,19	DMR 132 LN- 47AP
		<b>2270</b>		<b>46,6</b>	<b>62</b>	3500	114	196	145	89,2	86,9	4,80	0,19	DMR 132 LN- 47AR
			<b>2380</b>	<b>48,8</b>	<b>65</b>	3500	114	196	145	89,6	87,4	4,80	0,19	DMR 132 LN- 47AT
<b>1530</b>				<b>32,5</b>	<b>44</b>	2800	94	203	150	86,9	83,7	7,50	0,29	DMR 132 LN- 47BO
	<b>1620</b>			<b>34,4</b>	<b>46</b>	2800	94	203	150	87,4	84,4	7,50	0,29	DMR 132 LN- 47BP
		<b>1790</b>		<b>38,0</b>	<b>51</b>	2800	94	203	150	88,3	85,5	7,50	0,29	DMR 132 LN- 47BR
			<b>1870</b>	<b>39,7</b>	<b>53</b>	2800	93	203	150	88,7	86,0	7,50	0,29	DMR 132 LN- 47BT
<b>1240</b>				<b>26,8</b>	<b>36</b>	2400	79	206	152	85,1	81,5	11,00	0,44	DMR 132 LN- 472O
	<b>1310</b>			<b>28,3</b>	<b>38</b>	2400	79	206	152	85,7	82,2	11,00	0,44	DMR 132 LN- 472P
		<b>1450</b>		<b>31,3</b>	<b>42</b>	2400	79	206	152	86,8	83,6	11,00	0,44	DMR 132 LN- 472R
			<b>1530</b>	<b>33,1</b>	<b>44</b>	2400	79	206	152	87,3	84,2	11,00	0,44	DMR 132 LN- 472T

Form Factor	< 1.03	Excitation Power	1300 W	Operating Mode	S 1	Weight	250 kg
Mech. limit speed	4000 RPM	Excitation current at 310V	4.0 A	Type of protection	IP 23	Uncompensated	
Moment of inertia	0.16 kgm <sup>2</sup>	Insulation material class	H	Type of cooling	IC 06/17/37		

## Technical Data

### DMR 160 SN

400	Speed n Armature voltage Ua of:				Out- put	Out- put	n max electr.	Armature current	Torque	Torque	Effectivity		Induc- tivity	Armature circuit impedance	Order DesiDMRtion
	420	460	480	Pab							Pab	Ia			
[V]	[V]	[V]	[V]	[kW]	[hp]	[min-1]	[A]	[Nm]	[lbf ft]	[%]	[%]	[mH]	[Ohm]		
<b>3070</b>				<b>81,0</b>	<b>109</b>	4300	223	252	186	90,6	88,7	1,40	0,052	DMR 160 SN- 471O	
	<b>3230</b>			<b>85,2</b>	<b>114</b>	4300	223	252	186	90,9	89,1	1,40	0,052	DMR 160 SN- 471P	
		<b>3560</b>		<b>94,0</b>	<b>126</b>	4300	223	252	186	91,5	89,8	1,40	0,052	DMR 160 SN- 471R	
			<b>3720</b>	<b>98,0</b>	<b>131</b>	4300	223	252	186	91,7	90,1	1,40	0,052	DMR 160 SN- 471T	
<b>2750</b>				<b>75,0</b>	<b>101</b>	4100	207	261	193	90,8	88,7	1,80	0,065	DMR 160 SN- 271O	
	<b>2900</b>			<b>79,1</b>	<b>106</b>	4100	206	261	193	91,1	89,2	1,80	0,065	DMR 160 SN- 271P	
		<b>3190</b>		<b>87,0</b>	<b>117</b>	4100	206	261	193	91,7	89,9	1,80	0,065	DMR 160 SN- 271R	
			<b>3340</b>	<b>91,1</b>	<b>122</b>	4100	206	261	193	91,9	90,2	1,80	0,065	DMR 160 SN- 271T	
<b>2260</b>				<b>64,0</b>	<b>86</b>	3900	179	271	200	89,6	87,3	2,60	0,091	DMR 160 SN- 47AO	
	<b>2380</b>			<b>67,4</b>	<b>90</b>	3900	178	271	200	90,0	87,8	2,60	0,091	DMR 160 SN- 47AP	
		<b>2630</b>		<b>74,5</b>	<b>100</b>	3900	178	271	200	90,7	88,6	2,60	0,091	DMR 160 SN- 47AR	
			<b>2750</b>	<b>77,9</b>	<b>122</b>	3900	178	271	200	91,0	89,0	2,60	0,091	DMR 160 SN- 47AT	
<b>1780</b>				<b>53,0</b>	<b>71</b>	3200	149	284	209	88,9	86,1	4,00	0,144	DMR 160 SN- 47BO	
	<b>1880</b>			<b>56,0</b>	<b>75</b>	3200	149	284	209	89,4	86,7	4,00	0,144	DMR 160 SN- 47BP	
		<b>2070</b>		<b>61,6</b>	<b>83</b>	3200	149	284	209	90,1	87,6	4,00	0,144	DMR 160 SN- 47BR	
			<b>2170</b>	<b>64,6</b>	<b>87</b>	3200	149	284	209	90,4	88,1	4,00	0,144	DMR 160 SN- 47BT	
<b>1300</b>				<b>38,0</b>	<b>51</b>	2600	110	279	206	86,4	82,8	7,00	0,246	DMR 160 SN- 272O	
	<b>1370</b>			<b>40,0</b>	<b>54</b>	2600	110	279	206	86,9	83,4	7,00	0,246	DMR 160 SN- 272P	
		<b>1520</b>		<b>44,4</b>	<b>60</b>	2600	110	279	206	87,9	84,7	7,00	0,246	DMR 160 SN- 272R	
			<b>1590</b>	<b>46,5</b>	<b>62</b>	2600	110	279	206	88,3	85,2	7,00	0,246	DMR 160 SN- 272T	

Form Factor	< 1.03	Excitation Power	1920 W	Operating Mode	S 1	Weight	240 kg
Mech. limit speed	4500 RPM	Excitation current at 310V	6.2 A	Type of protection	IP 23	Uncompensated	
Moment of inertia	0.24 kgm <sup>2</sup>	Insulation material class	H	Type of cooling	IC 06/17/37		

**DMR 160 MN**

400	Speed n Armature voltage Ua of:			Out- put	Out- put	n max electr.	Armature current	Torque	Torque	Effectivity		Induc- tivity	Armature circuit impedance	Order DesiDMRtion
	420	460	480							eta A	eta tot			
[V]	[V]	[V]	[V]	[kW]	[hp]	[min-1]	[A]	[Nm]	[lbf ft]	[%]	[%]	[mH]	[Ohm]	
<b>2590</b>				<b>100</b>	<b>134</b>	3200	270	369	272	92,4	90,7	1,50	0,045	DMR 160 MN- Y7AO
	<b>2730</b>			<b>105</b>	<b>141</b>	3500	270	369	272	92,7	91,0	1,50	0,045	DMR 160 MN- Y7AP
		<b>3000</b>		<b>116</b>	<b>156</b>	3800	270	369	272	93,2	91,6	1,50	0,045	DMR 160 MN- Y7AR
			<b>3140</b>	<b>121</b>	<b>162</b>	3800	270	369	272	93,4	91,9	1,50	0,045	DMR 160 MN- Y7AT
<b>2120</b>				<b>84,0</b>	<b>113</b>	3900	233	378	279	90,3	88,3	2,10	0,068	DMR 160 MN- 471O
	<b>2230</b>			<b>88,4</b>	<b>119</b>	3900	232	378	279	90,7	88,8	2,10	0,068	DMR 160 MN- 471P
		<b>2460</b>		<b>97,5</b>	<b>131</b>	3900	232	378	279	91,3	89,6	2,10	0,068	DMR 160 MN- 471R
			<b>2580</b>	<b>102</b>	<b>137</b>	3900	232	378	279	91,6	89,6	2,10	0,068	DMR 160 MN- 471T
<b>1680</b>				<b>69,0</b>	<b>93</b>	3000	193	392	289	89,6	87,2	3,3	0,10	DMR 160 MN- Y72O
	<b>1770</b>			<b>72,7</b>	<b>97</b>	3000	192	392	289	90,0	87,7	3,3	0,10	DMR 160 MN- Y72P
		<b>1950</b>		<b>80,1</b>	<b>107</b>	3000	192	392	289	90,7	88,6	3,3	0,10	DMR 160 MN- Y72R
			<b>2050</b>	<b>84,2</b>	<b>113</b>	3000	192	392	289	91,0	89,0	3,3	0,10	DMR 160 MN- Y72T
<b>1220</b>				<b>50,0</b>	<b>67</b>	2400	143	391	288	87,4	84,3	5,9	0,19	DMR 160 MN- 47BO
	<b>1290</b>			<b>52,9</b>	<b>71</b>	2400	143	391	288	87,9	85,0	5,9	0,19	DMR 160 MN- 47BP
		<b>1420</b>		<b>58,2</b>	<b>78</b>	2400	143	391	288	88,8	86,1	5,9	0,19	DMR 160 MN- 47BR
			<b>1490</b>	<b>61,1</b>	<b>82</b>	2400	143	391	288	89,2	86,6	5,9	0,19	DMR 160 MN- 47BT
<b>880</b>				<b>37,5</b>	<b>50</b>	1800	110	407	300	85,0	81,2	10,4	0,32	DMR 160 MN- 272O
	<b>930</b>			<b>39,6</b>	<b>53</b>	1800	110	407	300	85,7	82,0	10,4	0,32	DMR 160 MN- 272P
		<b>1030</b>		<b>43,9</b>	<b>59</b>	1800	110	407	300	86,8	83,4	10,4	0,32	DMR 160 MN- 272R
			<b>1080</b>	<b>46,0</b>	<b>62</b>	1800	110	407	300	87,3	84,0	10,4	0,32	DMR 160 MN- 272T

Form Factor	< 1.03	Excitation Power	2100 W	Operating Mode	S 1	Weight	320 kg
Mech. limit speed	4500 RPM	Excitation current at 310V	6.7 A	Type of protection	IP 23	Uncompensated	
Moment of inertia	0.35 kgm <sup>2</sup>	Insulation material class	H	Type of cooling	IC 06/17/37		

## Technical Data

### DMR 160 LN

400	Speed n Armature voltage Ua of:				Out- put	Out- put	n max electr.	Armature current	Torque	Torque	Effectivity		Induc- tivity	Armature circuit impedance	Order DesiDMRtion
	420	460	480	Pab							Pab	Ia			
[V]	[V]	[V]	[V]	[kW]	[hp]	[min-1]	[A]	[Nm]	[lbf ft]	[%]	[%]	[mH]	[Ohm]		
<b>2730</b>				<b>122</b>	<b>164</b>	3300	334	427	315	91,5	89,6	1,10	0,033	DMR 160 LN- Y71O	
	<b>2870</b>			<b>128</b>	<b>172</b>	3300	333	427	315	91,7	90,0	1,10	0,033	DMR 160 LN- Y71P	
		<b>3160</b>		<b>141</b>	<b>189</b>	3300	333	427	315	92,3	90,7	1,10	0,033	DMR 160 LN- Y71R	
<b>2500</b>				<b>112</b>	<b>150</b>	3300	306	428	316	91,5	89,5	1,30	0,038	DMR 160 LN- W71O	
	<b>2630</b>			<b>118</b>	<b>158</b>	3300	306	428	316	91,8	89,9	1,30	0,038	DMR 160 LN- W71P	
		<b>2900</b>		<b>130</b>	<b>174</b>	3300	305	428	316	92,3	90,6	1,30	0,038	DMR 160 LN- W71R	
			<b>3030</b>	<b>136</b>	<b>182</b>	3300	305	428	316	92,6	90,9	1,30	0,038	DMR 160 LN- W71T	
<b>2020</b>				<b>95</b>	<b>127</b>	2500	260	449	331	91,4	89,1	2,00	0,056	DMR 160 LN- Y7AO	
	<b>2130</b>			<b>100</b>	<b>134</b>	2700	260	449	331	91,7	89,5	2,00	0,056	DMR 160 LN- Y7AP	
		<b>2340</b>		<b>110</b>	<b>148</b>	2900	259	449	331	92,3	90,2	2,00	0,056	DMR 160 LN- Y7AR	
			<b>2450</b>	<b>115</b>	<b>154</b>	3000	259	449	331	92,5	90,6	2,00	0,056	DMR 160 LN- Y7AT	
<b>1650</b>				<b>80,0</b>	<b>107</b>	3000	224	463	341	89,5	86,9	2,80	0,084	DMR 160 LN- 471O	
	<b>1740</b>			<b>84,4</b>	<b>113</b>	3000	223	463	341	89,9	87,4	2,80	0,084	DMR 160 LN- 471P	
		<b>1920</b>		<b>93,1</b>	<b>125</b>	3000	223	463	341	90,6	88,3	2,80	0,084	DMR 160 LN- 471R	
			<b>2010</b>	<b>97,5</b>	<b>131</b>	3000	223	463	341	90,9	88,7	2,80	0,084	DMR 160 LN- 471T	
<b>1080</b>				<b>53,0</b>	<b>71</b>	2100	152	469	346	87,2	83,5	6,20	0,183	DMR 160 LN- 27AO	
	<b>1140</b>			<b>55,9</b>	<b>75</b>	2100	152	469	346	87,7	84,1	6,20	0,183	DMR 160 LN- 27AP	
		<b>1260</b>		<b>61,8</b>	<b>83</b>	2100	152	469	346	88,6	85,3	6,20	0,183	DMR 160 LN- 27AR	
			<b>1320</b>	<b>64,8</b>	<b>87</b>	2100	152	469	346	89,0	85,9	6,20	0,183	DMR 160 LN- 27AT	

Form Factor	< 1.03	Excitation Power	2200 W	Operating Mode	S 1	Weight 410 kg Uncompensated
Mech. limit speed	3300 RPM	Excitation current at 310V	6.9 A	Type of protection	IP 23	
Moment of inertia	0.45 kgm <sup>2</sup>	Insulation material class	H	Type of cooling	IC 06/17/37	



**DMR 180 SN**

400 [V]	Speed n Armature voltage Ua of:			Out- put [kW]	Out- put [hp]	n max electr. [min-1]	Armature current [A]	Torque [Nm]	Torque [lbf ft]	Effectivity		Induc- tivity [mH]	Armature circuit impedance [Ohm]	Order DesiDMRtion
	420 [V]	460 [V]	480 [V]							eta A	eta tot			
<b>2950</b>				<b>138</b>	<b>185</b>	4000	375	447	447	92,1	90,8	0,90	0,029	DMR 180 SN- S71O
	<b>3110</b>			<b>146</b>	<b>196</b>	4000	375	447	447	92,4	91,1	0,90	0,029	DMR 180 SN- S71P
		<b>3420</b>		<b>160</b>	<b>215</b>	4000	375	447	447	92,9	91,7	0,90	0,029	DMR 180 SN- S71R
			<b>3570</b>	<b>167</b>	<b>224</b>	4000	374	447	447	93,1	91,9	0,90	0,029	DMR 180 SN- S71T
<b>2280</b>				<b>110</b>	<b>148</b>	4000	302	461	461	91,1	89,4	1,40	0,052	DMR 180 SN- 471O
	<b>2400</b>			<b>116</b>	<b>156</b>	4000	302	461	461	91,4	89,8	1,40	0,052	DMR 180 SN- 471P
		<b>2650</b>		<b>128</b>	<b>172</b>	4000	302	461	461	92,0	90,5	1,40	0,052	DMR 180 SN- 471R
<b>2030</b>				<b>100</b>	<b>134</b>	3000	276	470	470	90,6	88,8	1,70	0,063	DMR 180 SN- 271O
	<b>2140</b>			<b>105</b>	<b>141</b>	3000	276	470	470	90,9	89,2	1,70	0,063	DMR 180 SN- 271P
		<b>2360</b>		<b>116</b>	<b>156</b>	3000	276	470	470	91,6	90,0	1,70	0,063	DMR 180 SN- 271R
			<b>2470</b>	<b>122</b>	<b>164</b>	3000	276	470	470	91,8	90,3	1,70	0,063	DMR 180 SN- 271T
<b>1650</b>				<b>80,0</b>	<b>107</b>	2600	223	463	463	89,7	87,5	2,60	0,091	DMR 180 SN- W72O
	<b>1740</b>			<b>84,4</b>	<b>113</b>	2600	223	463	463	90,1	88,0	2,60	0,091	DMR 180 SN- W72P
		<b>1920</b>		<b>93,1</b>	<b>125</b>	3000	223	463	463	90,8	88,9	2,60	0,091	DMR 180 SN- W72R
			<b>2010</b>	<b>97,5</b>	<b>131</b>	3200	223	463	463	91,1	89,3	2,60	0,091	DMR 180 SN- W72T
<b>1070</b>				<b>53,5</b>	<b>72</b>	1900	156	477	477	85,7	82,8	5,50	0,20	DMR 180 SN- 472O
	<b>1130</b>			<b>56,5</b>	<b>76</b>	2300	156	477	477	86,3	83,5	5,50	0,20	DMR 180 SN- 472P
		<b>1250</b>		<b>62,5</b>	<b>84</b>	2300	156	477	477	87,4	84,8	5,50	0,20	DMR 180 SN- 472R

Form Factor	< 1.03	Excitation Power	2100 W	Operating Mode	S 1	Weight	370 kg
Mech. limit speed	4000 RPM	Excitation current at 310V	6.A	Type of protection	IP 23	Uncompensated	
Moment of inertia	0.41 kgm <sup>2</sup>	Insulation material class	H	Type of cooling	IC 06/17/37		

## Technical Data

### DMR 180 MN

400 [V]	Speed n Armature voltage Ua of:			Out- put Pab [kW]	Out- put Pab [hp]	n max electr. [min-1]	Armature current Ia [A]	Torque M [Nm]	Torque M [lbf ft]	Effectivity		Induc- tivity La [mH]	Armature circuit impedance Ra [Ohm]	Order DesiDMRtion
	420 [V]	460 [V]	480 [V]							eta A [%]	eta tot [%]			
<b>2580</b>				<b>150</b>	<b>201</b>	3000	407	555	409	92,0	90,6	0,90	0,028	DMR 180 MN- W71O
	<b>2720</b>			<b>158</b>	<b>212</b>	3000	407	555	409	92,3	91,0	0,90	0,028	DMR 180 MN- W71P
		<b>2990</b>		<b>174</b>	<b>233</b>	3000	407	555	409	92,8	91,6	0,90	0,028	DMR 180 MN- W71R
<b>2210</b>				<b>133</b>	<b>178</b>	3000	363	575	424	91,6	90,0	1,20	0,036	DMR 180 MN- S71O
	<b>2330</b>			<b>140</b>	<b>188</b>	3000	363	575	424	91,9	90,4	1,20	0,036	DMR 180 MN- S71P
		<b>2560</b>		<b>154</b>	<b>207</b>	3000	362	575	424	92,4	91,1	1,20	0,036	DMR 180 MN- S71R
			<b>2680</b>	<b>161</b>	<b>216</b>	3000	362	575	424	92,7	91,4	1,20	0,036	DMR 180 MN- S71T
<b>1710</b>				<b>107</b>	<b>143</b>	2600	296	598	441	90,4	88,5	1,90	0,063	DMR 180 MN- 471O
	<b>1800</b>			<b>113</b>	<b>152</b>	2800	296	598	441	90,7	88,9	1,90	0,063	DMR 180 MN- 471P
		<b>1990</b>		<b>125</b>	<b>168</b>	2800	296	598	441	91,4	89,8	1,90	0,063	DMR 180 MN- 471R
<b>1380</b>				<b>84,5</b>	<b>113</b>	2100	236	585	431	89,5	87,2	2,90	0,090	DMR 180 MN- Z71O
	<b>1460</b>			<b>89,4</b>	<b>120</b>	2300	237	585	431	90,0	87,8	2,90	0,090	DMR 180 MN- Z71P
		<b>1610</b>		<b>98,6</b>	<b>132</b>	2700	236	585	431	90,7	88,7	2,90	0,090	DMR 180 MN- Z71R
			<b>1680</b>	<b>103</b>	<b>138</b>	2700	235	585	431	91,0	89,0	2,90	0,090	DMR 180 MN- Z71T
<b>1050</b>				<b>66,0</b>	<b>89</b>	1800	189	600	443	87,3	84,5	4,70	0,146	DMR 180 MN- S72O
	<b>1110</b>			<b>69,8</b>	<b>94</b>	2000	189	600	443	87,8	85,2	4,70	0,146	DMR 180 MN- S72P
		<b>1230</b>		<b>77,3</b>	<b>104</b>	2100	189	600	443	88,8	86,3	4,70	0,146	DMR 180 MN- S72R
			<b>1290</b>	<b>81,1</b>	<b>109</b>	2100	189	600	443	89,2	86,8	4,70	0,146	DMR 180 MN- S72T

Form Factor	< 1.03	Excitation Power	2300 W	Operating Mode	S 1	Weight	460 kg
Mech. limit speed	3000 RPM	Excitation current at 310V	7.A	Type of protection	IP 23	Uncompensated	
Moment of inertia	0.52 kgm <sup>2</sup>	Insulation material class	H	Type of cooling	IC 06/17/37		

### DMR 180 LN

400 [V]	Speed n Armature voltage Ua of:			Out- put [kW]	Out- put [hp]	n max electr. [min-1]	Armature current [A]	Torque M [Nm]	Torque M [lbf ft]	Effectivity		Induc- tivity [mH]	Armature circuit impedance [Ohm]	Order DesiDMRtion
	420 [V]	460 [V]	480 [V]							eta A [%]	eta tot [%]			
<b>2200</b>				<b>145</b>	<b>194</b>	2400	395	629	464	91,8	90,2	1,00	0,031	DMR 180 LN- W71O
	<b>2320</b>			<b>153</b>	<b>205</b>	2400	395	629	464	92,1	90,6	1,00	0,031	DMR 180 LN- W71P
<b>1880</b>				<b>130</b>	<b>174</b>	2400	356	660	487	91,4	89,7	1,40	0,040	DMR 180 LN- S71O
	<b>1980</b>			<b>137</b>	<b>184</b>	2400	355	660	487	91,8	90,1	1,40	0,040	DMR 180 LN- S71P
		<b>2180</b>		<b>151</b>	<b>202</b>	2400	355	660	487	92,3	90,8	1,40	0,040	DMR 180 LN- S71R
			<b>2280</b>	<b>158</b>	<b>212</b>	2400	355	660	487	92,6	91,1	1,40	0,040	DMR 180 LN- S71T
<b>1450</b>				<b>104</b>	<b>139</b>	2200	290	685	505	89,7	87,5	2,20	0,070	DMR 180 LN- 471O
	<b>1530</b>			<b>110</b>	<b>148</b>	2400	290	685	505	90,1	88,1	2,20	0,070	DMR 180 LN- 471P
		<b>1690</b>		<b>121</b>	<b>162</b>	2400	290	685	505	90,8	88,9	2,20	0,070	DMR 180 LN- 471R
			<b>1770</b>	<b>127</b>	<b>170</b>	2400	290	685	505	91,1	89,3	2,20	0,070	DMR 180 LN- 471T
<b>1040</b>				<b>74,0</b>	<b>99</b>	1600	211	679	501	87,7	84,9	4,20	0,125	DMR 180 LN- W72O
	<b>1100</b>			<b>78,3</b>	<b>105</b>	1900	211	679	501	88,2	85,5	4,20	0,125	DMR 180 LN- W72P
		<b>1210</b>		<b>84,1</b>	<b>113</b>	1900	210	679	501	89,1	86,6	4,20	0,125	DMR 180 LN- W72R
			<b>1270</b>	<b>90,4</b>	<b>121</b>	1900	210	679	501	89,5	87,1	4,20	0,125	DMR 180 LN- W72T

Form Factor	< 1.03	Excitation Power	2450 W	Operating Mode	S 1	Weight	530 kg
Mech. limit speed	2450 RPM	Excitation current at 310V	7.5A	Type of protection	IP 23	Uncompensated	
Moment of inertia	0.61 kgm2	Insulation material class	H	Type of cooling	IC 06/17/37		

## Bearings and Shaft Loading

---

### Bearings and Shaft Loading

All machines have rolling-contact bearings. Normally, the floating bearing is on the D side and the locating bearing is on the non-drive side. Machines with roller bearings on the D side are only available for increased radial force. When placing your order, please state the radial forces.

#### Bearing Assignment of Ball Bearings for D Side

Size	D side	N side
112	6210 2ZR C3	6209 2ZR C3
132	6212 2ZR C3	6211 2ZR C3
160	6214 2ZR C3	6212 2ZR C3
180	6213 C3	6310 2RSR C3

#### Bearing Assign. of Roller Bearings for D Side

Size	D side	N side
112	NU 210 E	6209 2ZR C3
132	NU 212 E	6211 2ZR C3
160	NU 214 E	6212 2ZR C3
180	NU 2213 E	6310 2RSR C3

#### Relubrication Intervals

Sizes 112-180 - permanently lubricated

In the case of versions with ball bearings on the drive side, lubrication intervals can increase by one-and-a-half times.

The lubrication intervals are based on bearing manufacturer data for normal operating conditions. Use only lithium base-saponified special rolling-contact bearing grease for initial or regreasing.

#### Determining the radial forces $F_R$

When using belt pulleys, the radial load is calculated according to the following formula:

$$F_R = k \frac{2 \cdot 10^7 \cdot P}{n \cdot D} \text{ [N]}$$

$P$  = nominal power in kW  
 $n$  = rated RPM speed in RPM  
 $D$  = disk diameter in mm

By approximation, the belt tension factor,  $k$ , is as follows:

$k = 1.8 \dots 2.5$  for V-belts

$k = 2.2 \dots 3.5$  for flat belts

(Observe the information provided by the belt manufacturer!)

To ensure safe transmission of the torque, it is necessary to exploit the feather key's entire bearing length. Ignoring this can lead to the risk of too high a level of compressive load per unit area on the feather key, which can result in a motor defect. Apart from this, when mounting drive elements (e.g. belt pulleys) you must always push them all the way to the shaft collar on the shaft end. Ignoring this can lead to the risk of the shaft breaking!

#### Permissible Radial Forces $F_R$ at the Shaft End

All the bearings have rated service lives of approximately 20,000 operating hours. In this connection, you must not exceed the loading values stated below. The stated permissible radial forces  $F_R$  apply only to motors that are installed horizontally without additional axial forces. If axial forces occur, you must consult the manufacturer.

Sample diagram

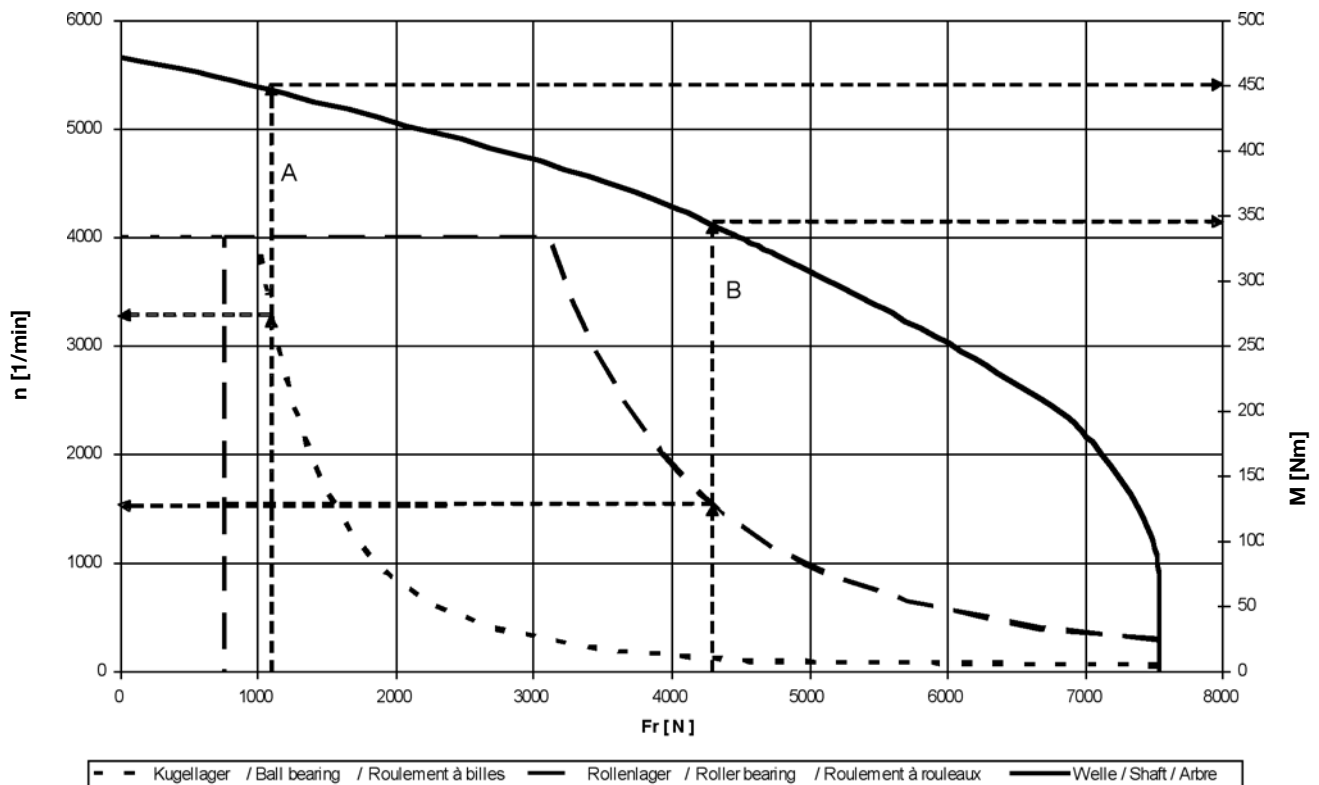

**Explanation to the sample diagram**

Force applied to end of shaft end (in case of force applied to middle of shaft end  $Fr \times 1.1$ ) bearing life 20,000 h; shaft end with feather key groove

**Case A – ball bearings:**

Using the application's radial force,  $Fr$ , you can determine in the ball bearing characteristic curve the bearing's maximum RPM speed.

Radial force 1100 N => maximum RPM speed 3250 RPM

The maximum torque that can still be transmitted results from the shaft characteristic curve.

Radial force 1100 N => torque that can still be transmitted 450 Nm

**Case B – roller bearings:**

Using the application's radial force,  $Fr$ , you can determine in the roller bearing characteristic curve the bearing's maximum RPM speed.

Radial force 4300 N => maximum RPM speed 1500 RPM

The maximum torque that can still be transmitted results from the shaft characteristic curve.

Radial force 4300 N => torque that can still be transmitted 345 Nm

The roller bearing needs a minimum radial force of 800 N to ensure this bearing service life.

DMR.112.N

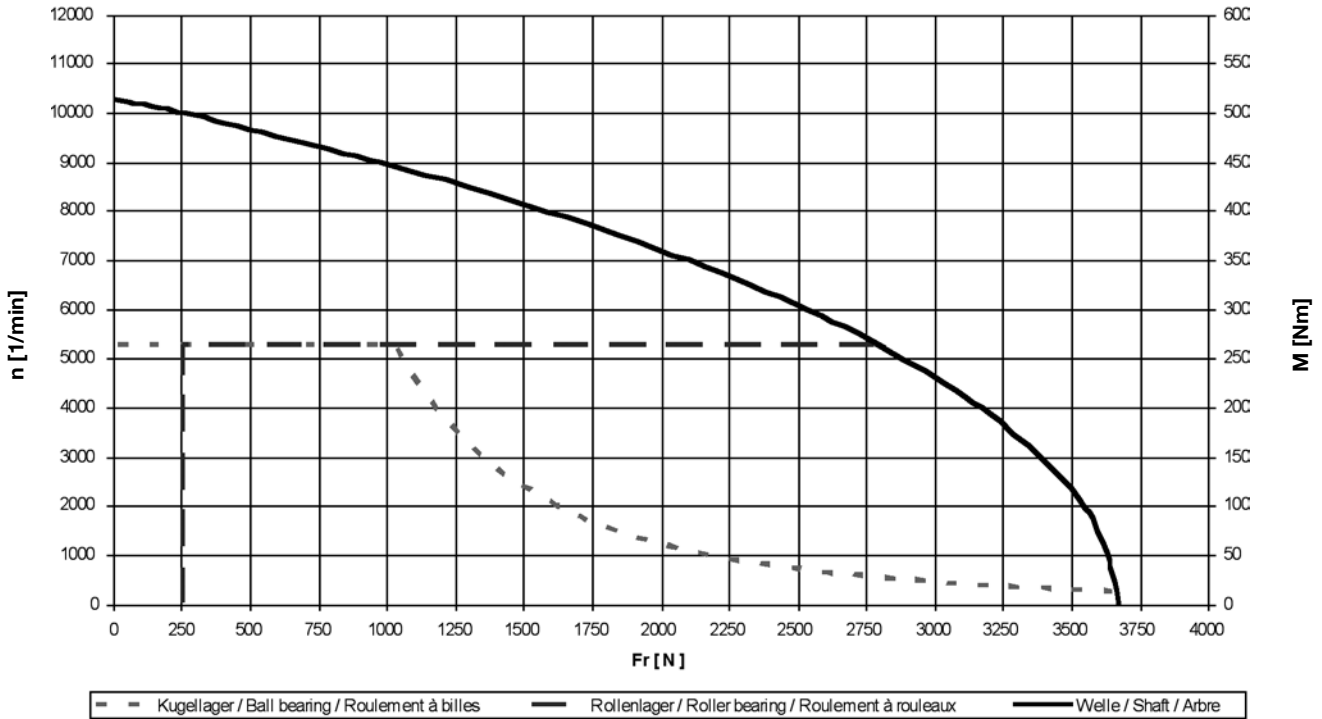

DMR.132.N

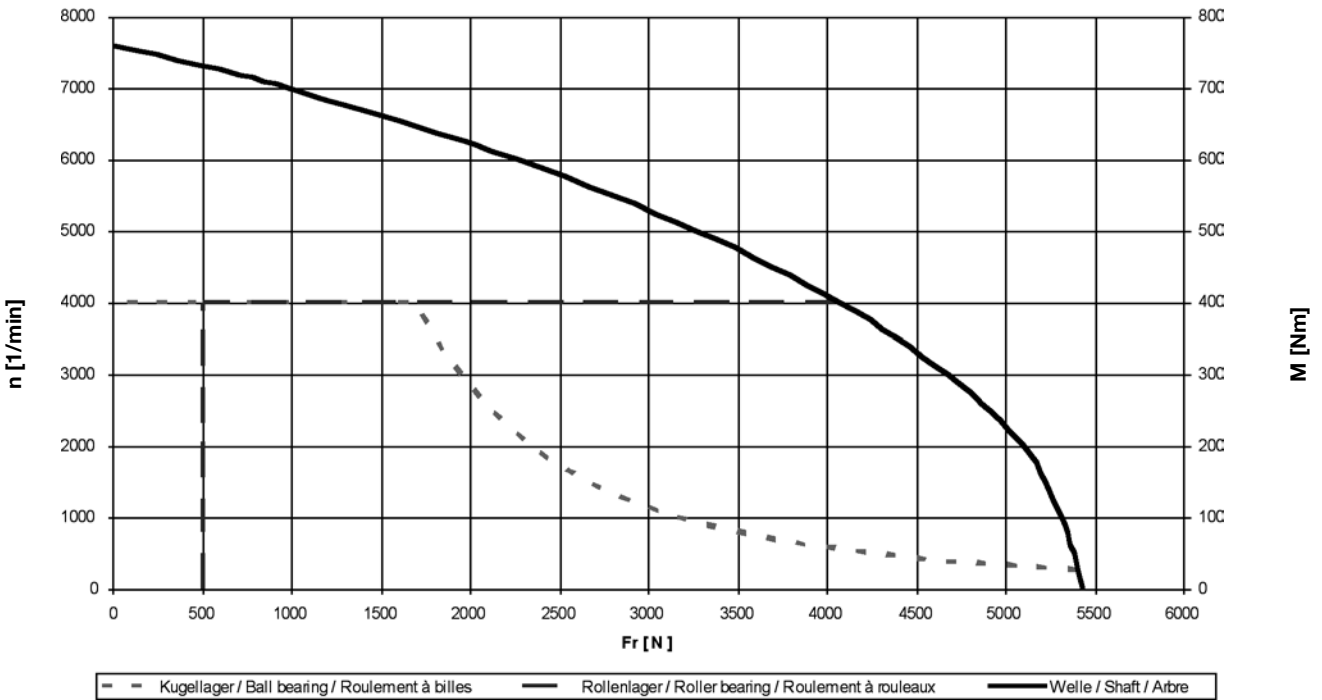



DMR. 160 .N

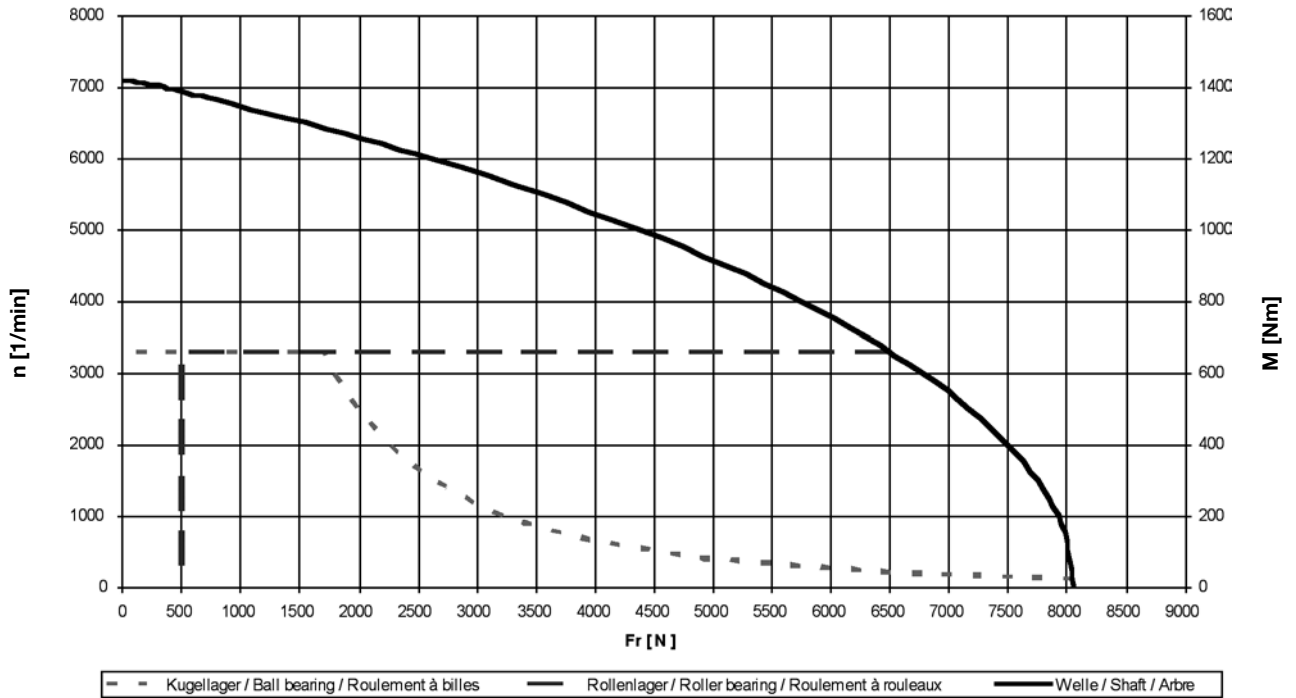

DMR. 180 .N

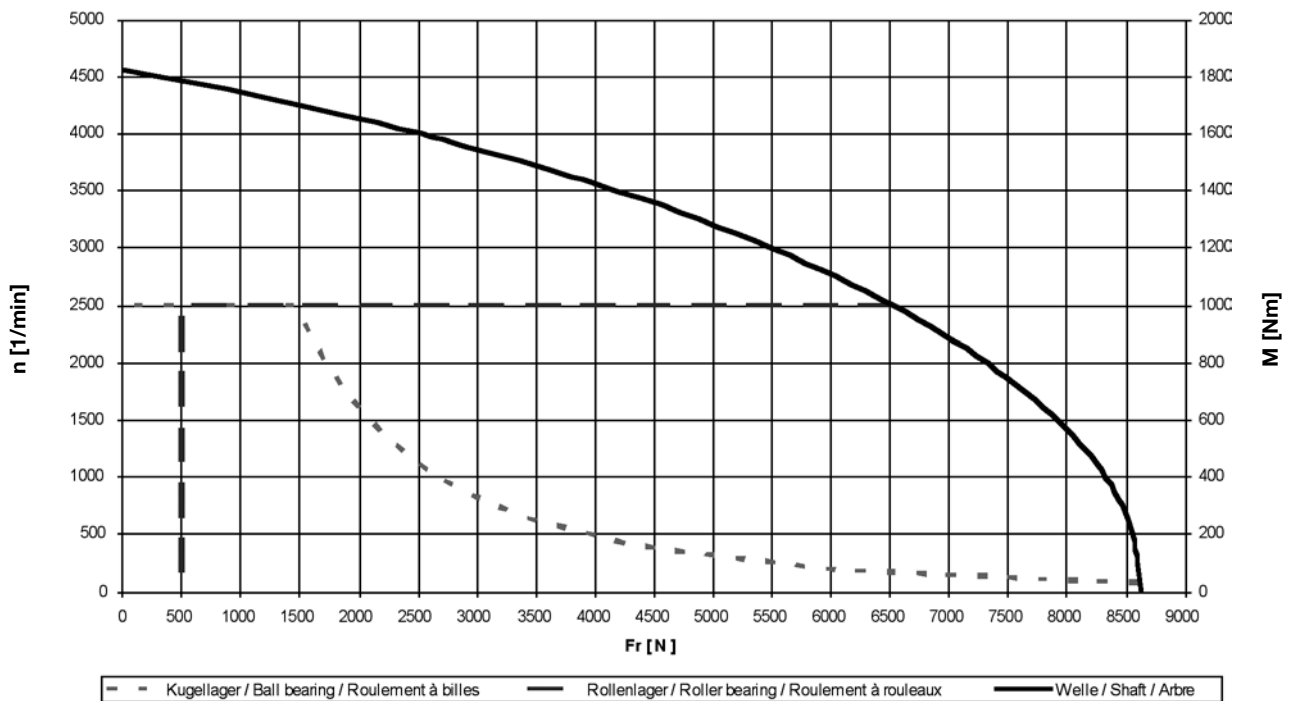

## Connection - Terminal Designation

### Temperature Monitoring

#### Brush monitoring

### Connection - Terminal Designation

DC machines	Machine winding of type of winding or conductor in DC supply network	Connection designations according to DIN VDE 0530, Part 8, adapted to IEC 60034-8
	Armature winding	A1 - A2
	Commutating winding	B1 - B2
	Commutating pole winding with compensating winding	C1 - C2
	Series field winding	D1 - D2
	Shunt field winding	E1 - E2
	Field winding (separately excited)	F1 - F2
DC supply network	Positive conductor	L +
	Negative conductor	L -
	Middle conductor	M

### Temperature Monitoring

#### Thermal protectors

As standard, motors are fitted with two thermal protectors for temperature monitoring one of which is in the commutating pole and the other in the field winding for switching off. On request, it is also possible to use PTC thermistors, KTY 84 temperature sensors or Pt100 measuring shunts. You can also use further temperature monitoring facilities, e.g. for alerts.

AC cos  $\varphi$  1.0 250V 2.5A; 500V 0.75A; AC cos  $\varphi$  0.6 250V 1.6A; 500V 0.5A; DC 24V 1.6A

The contacts are implemented as NC contacts.

#### Temperature detector (option)

KTY84 - 130

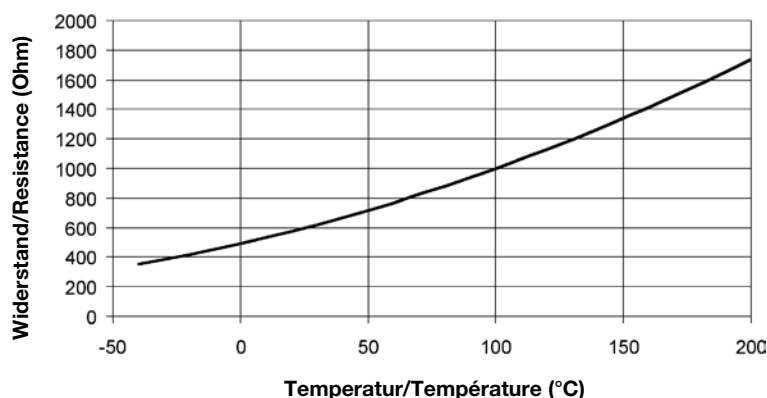

The KTY 84-130 temperature detector continuously monitors the motor temperature. Feeding a measuring current of 2 mA to the detector yields the resistance curve shown above.

#### Brush monitoring

With the motors, you can optionally install potential-free microswitches to monitor the remaining length of the carbon brushes.

Switching capacity of the microswitches:

Resistive load: 28 V DC - 7 A or 220 V AC - 3 A; Inductive load: 28 V DC - 4 A or 220 V AC - 2 A

Important: Operating voltage at least 12 -28 V, minimum current per contact of 15 mA;

The contacts open when the carbons are worn down.

**Noise level**

(For internally cooled motors)

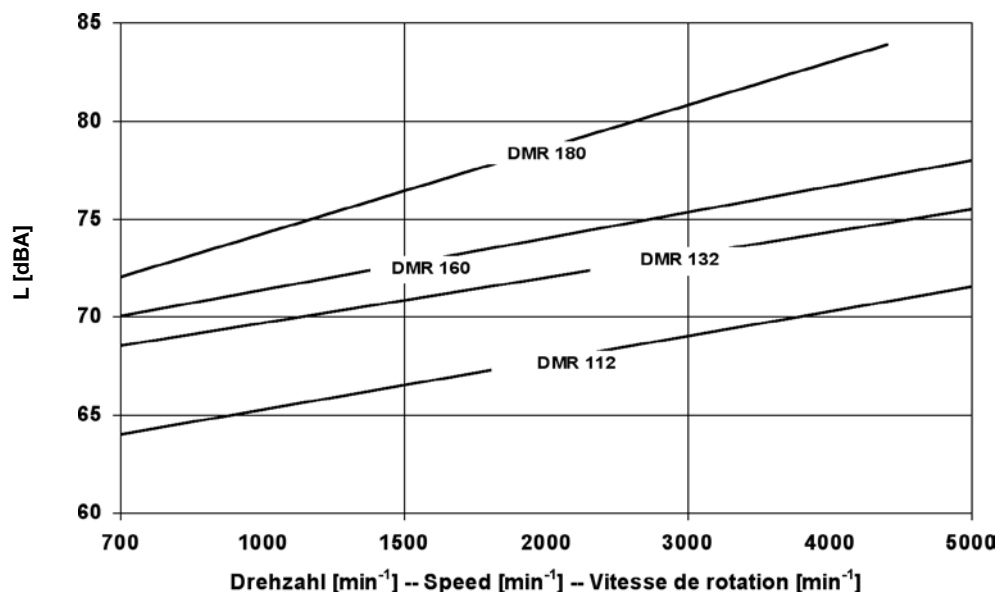

The internally ventilated motors do not exceed the limit values stipulated in EN 60034 -9  
A sound absorber reduces the noise level by 3 dBA.

**Vibration severity**

Vibration class DIN EN 60034 -14	Speed [RPM]	Size	
		112-132 V <sub>eff</sub> [mm/s]	160-180 V <sub>eff</sub> [mm/s]
N (Normal)	600 - 1800	1.8	2.8
	1800 - 3600	1.8	2.8
	3600 - 6000	2.8	4.5
	6000 - 7500	4.5	-
R* (Reduced)	600 - 1800	0.71	1.12
	1800 - 3600	1.12	1.8
	3600 - 6000	1.8	2.8
	6000 - 7500	2.8	-
S* (Special)	600 - 1800	0.45	0.71
	1800 - 3600	0.71	1.12
	3600 - 6000	1.12	1.8
	6000 - 7500	1.8	-

\* R and S can only be executed with ball bearing.

To take into consideration the lifetimes of the brushes and the commutator as well as the bearing service life, you must limit the vibration values at the motor's place of installation that come from the driven machine and from the environment. The following maximum values (which are based on VDI 2056) are permissible. The values are measured at the motor's four test points.

Size	112 to 160	180
	V <sub>eff</sub> [mm/s]	V <sub>eff</sub> [mm/s]
Max. permissible vibration severity	4.5	7.1

The motors are vibration-resistant at up to 3 g. Higher loads are possible on request.

## Cooling

---

### Cooling

DMR motors have a radial separately driven fan mounted on the side or at the top. This fan blows the air into the motor on the N side and out via the lateral openings in the D end shield.

For the force ventilated version of DMR, an external can unit supplies the cooling air to the motor via pipes. Refer to the table below for the amount of cooling air and the pressure.

#### Necessary cooling air volume and pressure

Size	Air Volume [m <sup>3</sup> /s]	Pressure Head [Pa]
112	0,10	380
132	0,22	800
160	0,32	1200
180	0,40	1200

The stated values apply to the direction of air flow from the N side to the D side.

In the opposite direction, approximately 10% higher air volumes are needed.

If the cooling air is to be fed in or out via a pipe, the fall in pressure in the piping system must not be greater than 5% of the pressure head from this table.

#### Fan assignment to motor

Size	Fan type	Nominal current [A]
112	BFB 398	0,33
132	BFB 635	1,4
160	BFB 752	3,8
180	BFB 752	3,8

Fan motors are rated as-standard for  $\Delta/Y$  200-265/345-460 V 50/60 Hz.

The stated nominal currents are maximum values.

#### Air flow monitoring

To ensure that the motor functions correctly, you must ensure that it is cooled adequately.

To monitor the flow of cooling air, you can optionally install an air flow monitoring facility in the blower.

Switching capacity of the microswitches: Resistive load  $\cos \varphi$  1: to 30 V DC 0.1 A or 30 - 250 V AC 5 A

Inductive load  $\cos \varphi$  0.6: to 30 V DC 0.1 A or 30 - 250 V AC 3 A

The contacts open when the air throughflow is too low.

For motor type	Brake type	Brake torque			Input power	max. perm. switching energy Wperm. per switching operation			Switching power P <sub>perm.</sub>	Disengaging time	Engaging time	Inertia	max. perm. speed	Weight
		[Nm]			[W]	[J]			[kJ/h]	[s]	[ms]	[kgm <sup>2</sup> ]	[min <sup>-1</sup> ]	[kg]
		Operating brake	Holding brake	Peak load brake		Operating brake	Holding brake	Peak load brake	for operating brake	Switching operation	Indiv. braking	Indiv. braking		
		[M2]	[M4]	[M4]										
<b>GN. 112</b>	SB 100	60	100	60	106	5000	18000	70000	560	180	250	0.0015	3500	9.5
<b>GN. 132</b>	SB 200	135	200	140	170	8000	20000	90000	630	225	300	0.0040	3000	13
<b>GN. 160</b>	SB 200	135	200	140	170	8000	20000	90000	630	225	300	0.0040	3000	13

For use as a holding brake the following must be observed:

Brake has a considerably increased brake torque

3 emergency stops (individual braking operations) per hour possible if evenly distributed

Switching times values are valid for switching on the AC side, in a cold state, with basic air gap and holding brake

Disengaging time – Time until the brake has completely disengaged (brake without torque)

Engaging time – Time until the brake torque is reached

M2 ... dynamic torque, M4 ... static torque

All information are valid for the installation on a horizontal shaft

The supplier must be contacted before vertical installation.

Requirements other than those indicated on request.

### Braking time / switching energy / switching capacity

It is useful to check that the brake is suited for its application. To do this, the brake energy and braking power must be determined.

### Determining the braking time

$t_B$	$\frac{\sum J \cdot n_1}{9,55 \cdot (M_B \pm M_L)} + t_0$ in s
$\sum J$	Total moment of inertia in kgm <sup>2</sup> = J <sub>mot</sub> + J <sub>zus</sub> (relative to the motor shaft)
J <sub>mot</sub>	Motor moment of inertia in kgm <sup>2</sup>
J <sub>zus</sub>	Additional moment of inertia in kgm <sup>2</sup> (referred to the motor shaft)
$\Delta n$	Motor speed in RPM
M <sub>B</sub>	Braking torque in Nm
M <sub>L</sub>	Load torque in Nm (positively calculated if it decelerates, negatively calculated if it accelerates)
t <sub>0</sub>	Time in s from the switching instant to the full extent of the braking torque (response time)
i	Number of working cycles per hour

## Brake assignment

### Encoder

#### Determining the switching energy and switching capacity

##### Switching energy:

$$W_R = \frac{\sum J \cdot \Delta n^2}{182.4} \cdot \frac{M_B}{(M_B \pm M_L)} \quad \text{in } \frac{\text{Joule}}{\text{Switching op.}}$$

$$W_{Rperm} \leq \text{Value from table}$$

##### Switching capacity:

$$P_R = \frac{W_R \cdot i}{1000} \quad \text{in } \frac{\text{kJ}}{\text{h}}$$

$$P_{Rperm} \leq \text{Value from table}$$

In most cases,  $t_0$  is negligible. If this is not the case and the time  $t_0$  must be reduced, you can achieve this by interrupting the magnet circuit on the DC side. However, this measure must be known before dimensioning the brake motor.

#### Brake supply

Normal voltage: 24; 96 - 120; 176V- (other voltages on request),

- 24 V: Supply with transformer and rectifier,
- 96 – 120 and 176 V: Supply using brake supply unit

The brakes can alternatively be equipped with microswitch or manually de-activated.

Switching capacity of microswitches

Ohmic load up to 30 V DC - 5 A or 250 V AC - 5 A

Inductive load up to 30 V DC -3 A or 250 V AC -2 A

The contact ratings apply to silver contacts

### Encoder

#### Direct voltage tachometers

Type	Mounting	Direct voltage at 1000 RPM [V]	$n_{Max}$ [RPM]
GHT S 46	Hollow shaft	60	4000
REO 444 R	Coupling	60	12000
TDP 0.2 T-4	Coupling	60	9000

#### Pulse encoder

Type	Mounting	Number of pulses per revolution	Maximum frequency [ kHz ]	$n_{Max}$ [RPM]	Signal level [V]
DGS 60	Coupling	125 to 5000	200	6000	5/9...30
POG 9	Coupling	1 to 1250	120	6000	9...30
RSI 593 PPS/CLS	Coupling	1 to 5000	200	6000	9...30

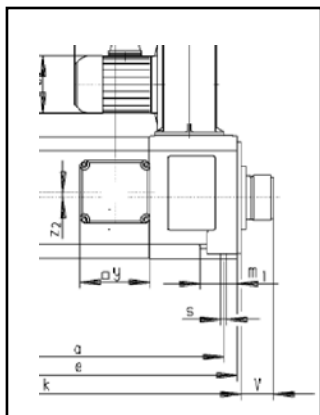

Encoder	V
REO 444 R1	215
TDP 0.2	225
GHTS	75
RSI 593 PPS/CLS	225
POG 9	185
DGS 60	90



## Structural forms

The following designs are possible:

- IM B3, B6, B7, B8, B3/B5
- Sizes 112-160 can be used in B5 to a maximum of vibration-resistant up to 3 g.
- IM V5, V6, V1/V5, V3/V6.
- All normal versions of V structural forms can only be supplied in IP20 type of protection.
- Higher types of protection on request.

### Structural forms according to DIN EN 60034

IEC Code I	IEC Code II
IM B 3	IM 1001
IM B 5	IM 3001
IM B 6	IM 1051
IM B 7	IM 1061
IM B 8	IM 1071
IM B 35	IM 2001
IEC Code I	IEC Code II
IM V 1	IM 3011
IM V 3	IM 3031
IM V 5	IM 1011
IM V 6	IM 1031
IM V 15	IM 2011

Other structural forms on request.

## Dimensional drawings

### Dimensional drawings

#### DMR 112 - 180 N (IM B3)

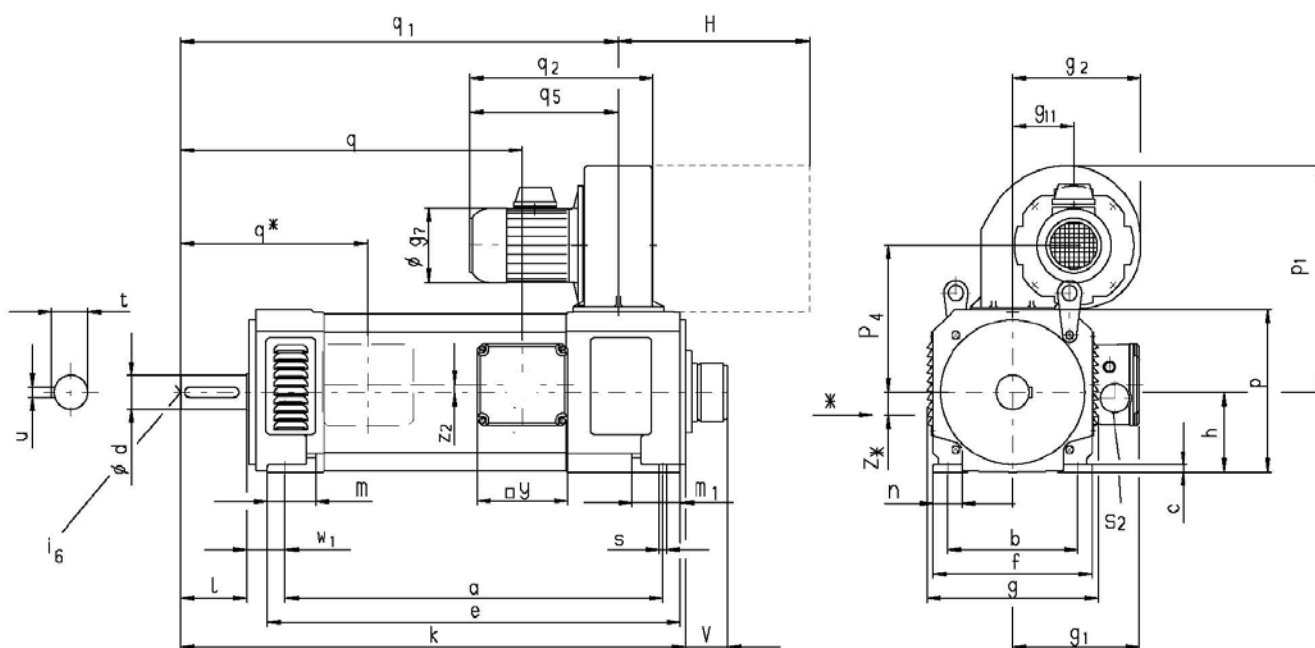

\* Dimensions with fan installed at side

Size	Shaft						Pedestal									Flange									
	d	l	t	u	i <sub>6</sub>	w <sub>1</sub>	a	b	c	e	f	s	m/m <sub>1</sub>	n	a <sub>1</sub>	b <sub>1</sub>	c <sub>1</sub>	e <sub>1</sub>	f <sub>1</sub>	i <sub>2</sub>	s <sub>1</sub>	a <sub>2</sub>	z	A/B	
112 SN	42	110	45	12	M16	56	460	190	10	490	220	12	59/46	50	300	230	14	265	4	110	14	240	4	A	
112 MN							510			540															
112 LN							570			600															
132 KN	48	110	51,5	14	M16	63	460	216	12	489	264	12	66/49	57	350	250	16	300	5	110	18	260	4	A	
132 SN							510			539															
132 MN							590			619															
132 LN							690			719															
160 SN	60	140	64	18	M20	70	614	254	12	653	312	14	85/60	65	400	300	20	350	5	140	18	312	4	A	
160 MN							724			763															
160 LN							834			873															
180 SN	65	140	69	18	M20	121	392	279	16	432	328	15	57	65	400	300	15	350	5	140	18	-	4	B	
180 MN							502			542															
180 LN							572			612															

DMR 112 - 180 N (IM B35)

Positions of flange's drilled holes

Version A

Version B

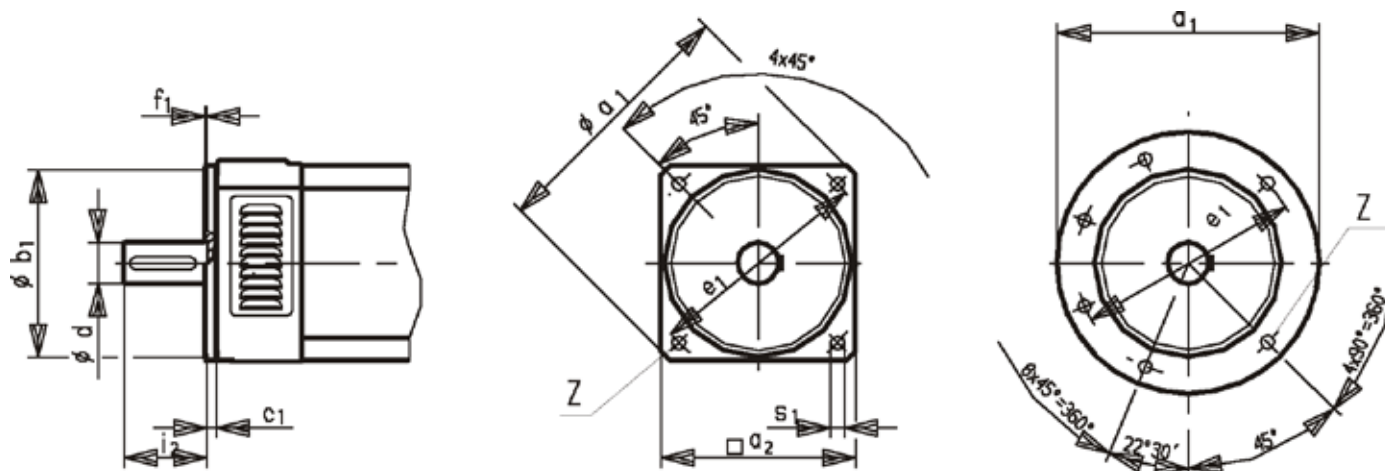

Centring in shaft ends according to DIN 332 shape D  
Version with a second shaft end on request

Fittings of shaft ends according to DIN 748 T3  
Flange version according to DIN 42948  
Forced ventilation can be rotated by 180°

Motor																			fan		* Dim. with fan mounted at side						
g	g <sub>1</sub>	g <sub>2</sub>	g <sub>7</sub>	g <sub>11</sub>	h	k	k <sub>2</sub>	p	p <sub>1</sub>	p <sub>4</sub>	q	q'	q <sub>1</sub>	q <sub>2</sub>	q <sub>5</sub>	S <sub>2</sub>	y	z <sub>2</sub>	H	Type	g' <sub>2</sub>	g' <sub>11</sub>	p' <sub>1</sub>	p' <sub>4</sub>	q' <sub>1</sub>	z'	
245	200	173	108	78	112	652	725	230	310	205	388	314	558	236	185	2M40	190	0	311	BFB 398	173	78	330	225	558	0	
						702	775				438		608			1M20									608		
						762	835				498		668													668	
285	235	237	145	114	132	659	732	270	410	252	362	349	560	346	277	2M50	224	0	460	BFB 635	237	114	430	272	560	0	
						709	782				412		610			2M25										610	
						789	862				492		690													690	
						889	962				592		790													790	
340	265	269	179	125	160	856	930	324	480	300	522	390	738	387	317	2M50	224	0	570	BFB 752	269	125	495	315	722	0	
						966	1040				632		848			2M25										832	
						1076	1150				742		958													942	
385	380	269	179	125	180	944	1015	370	500	320	536	379	794	387	317	6M32	330	58.5	570	BFB 752	269	125	505	325	784	0	
						1054	1125				646		904			3M25										894	
						1124	1195				716		974													964	

## Dimensional drawings

### DMR 112 - 180 N (motor with brake, IM B3)

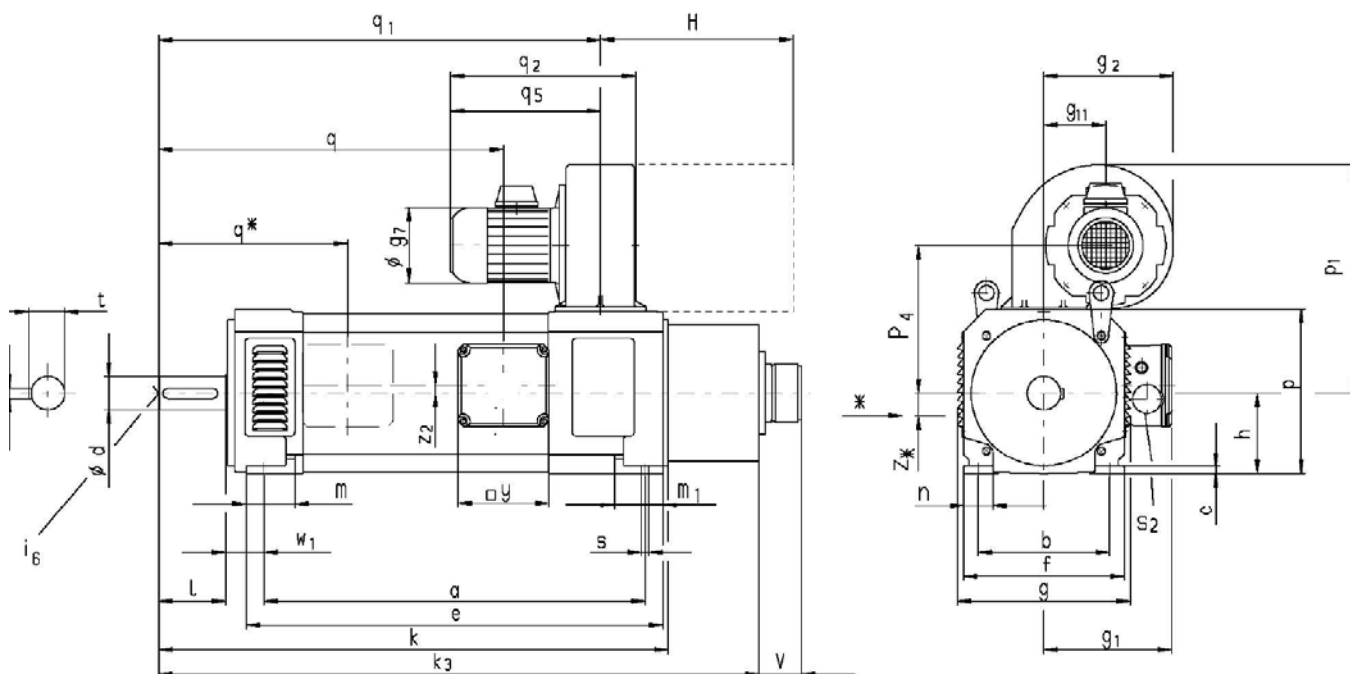

\* Dimensions with fan installed at side

Size	Shaft						Pedestal								Flange									
	d	l	t	u	i <sub>6</sub>	w <sub>1</sub>	a	b	c	e	f	s	m/m <sub>1</sub>	n	a <sub>1</sub>	b <sub>1</sub>	c <sub>1</sub>	e <sub>1</sub>	f <sub>1</sub>	i <sub>2</sub>	s <sub>1</sub>	a <sub>2</sub>	z	A/B
112 SN	42	110	45	12	M16	56	460	190	10	490	220	12	59/46	50	300	230	14	265	4	110	14	240	4	A
112 MN							510			540														
112 LN							570			600														
132 KN	48	110	51,5	14	M16	63	460	216	12	489	264	12	66/49	57	350	250	16	300	5	110	18	260	4	A
132 SN							510			539														
132 MN							590			619														
132 LN							690			719														
160 SN	60	140	64	18	M20	70	614	254	12	653	312	14	85/60	65	400	300	20	350	5	140	18	312	4	A
160 MN							724			763														
160 LN							834			873														
180 SN	65	140	69	18	M20	121	392	279	16	432	328	15	57	65	400	300	15	350	5	140	18	-	4	B
180 MN							502			542														
180 LN							572			612														

DMR 112 - 180 N (motor with brake, IM B35)

Positions of flange's drilled holes  
Version A                      Version B

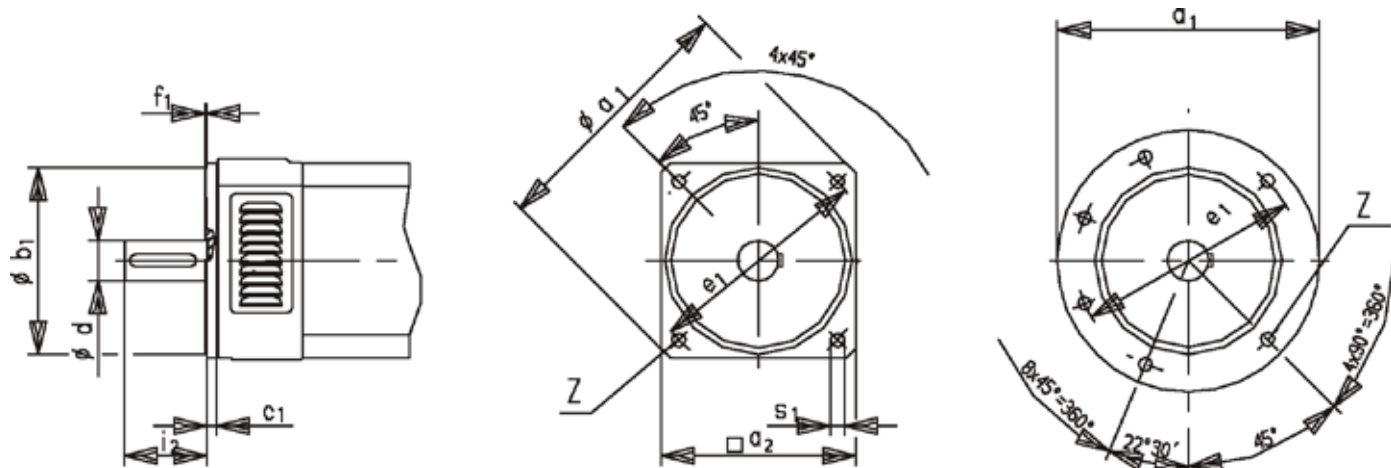

Centring in shaft ends according to DIN 332 shape D Version  
with a second shaft end on request  $k_3$  with brake

Fittings of shaft ends according to DIN 748 T3  
Flange version according to DIN 42948  
Forced ventilation can be rotated by 180°

Motor																				fan		* Dim. w. fan mounted at side				
g	g <sub>1</sub>	g <sub>2</sub>	g <sub>7</sub>	g <sub>11</sub>	h	k	k <sub>3</sub>	p	p <sub>1</sub>	p <sub>4</sub>	q	q'	q <sub>1</sub>	q <sub>2</sub>	q <sub>5</sub>	S <sub>2</sub>	y	z <sub>2</sub>	H	Typ	g' <sub>2</sub>	g' <sub>11</sub>	p' <sub>1</sub>	p' <sub>4</sub>	q' <sub>1</sub>	z'
245	200	173	108	78	112	652	755	230	310	205	385	317	558	230	185	2M40	190	0	311	BFB 398	173	78	330	225	558	0
						702	805				435	608				1M20									608	
						762	865				495	668													668	
285	235	237	145	114	132	659	770	270	410	252	360	352	560	346	277	2M50	224	0	460	BFB 635	237	114	430	272	560	0
						709	820				410	610				2M25									610	
						789	900				490	690													690	
						889	1000				590	790													790	
340	265	269	179	125	160	856	970	324	480	300	520	382	738	387	317	2M50	224	0	570	BFB 752	269	125	495	315	722	0
						966	1080				630	848				2M25									832	
						1076	1190				740	958													942	
385	380	269	179	125	180	944		370	500	320	536	379	794	387	317	6M32	330	58,5	570	BFB 752	269	125	505	325	784	0
						1054					646	904				3M25									894	
						1124					716	974													964	

## Dimensional drawings

### DMR 112 – 160 N

#### Drawings for motors with forced ventilation (IC17/IC37)

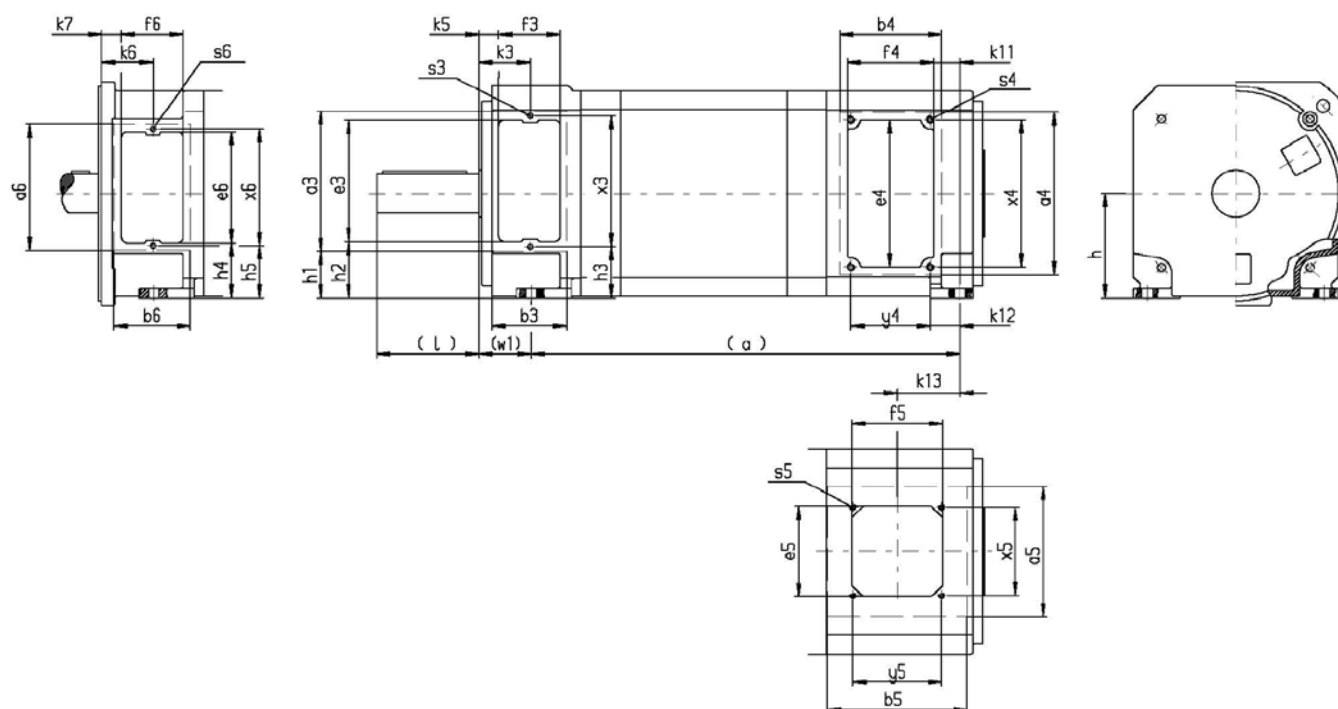

DMR	a6	b6	e6	f6	h4	h5	k6	k7	s6	x6	
112	135	82	113	66	62	56	55	21	M6	125	
132	160	95	129	72	75	68	63	27	M6	144	
160	188	115	164	95	82	76	74,5	27	M6	176	
DMR	a5	b5	e5	f5	k13	s5	x5	y5	h		
112	150	150	97	97	67,5	M6	95	95	112		
132	170	170	112	112	73	M8	126	151	132		
160	200	200	124	124	86,5	M8	144	151	160		
DMR	a4	b4	e4	f4	k11	k12	s4	x4	y4		
112	174	110	158	93	28	32	M8	158	85		
132	200	128	180	105	29	29	M8	180	110		
160	250	150	232	124	40	52	M8	232	100		
DMR	a3	b3	e3	f3	h1	h2	h3	k3	k5	s3	x3
112	150	80	124	66	50	63,5	55	55	21	M6	140
132	170	93	143	75	61,5	75	68	61,5	24	M6	157
160	217	110	181	90	70	88	81	77	32	M6	195

**DMR 180 N**

**Drawings for forced ventilation (IC17/IC37)**

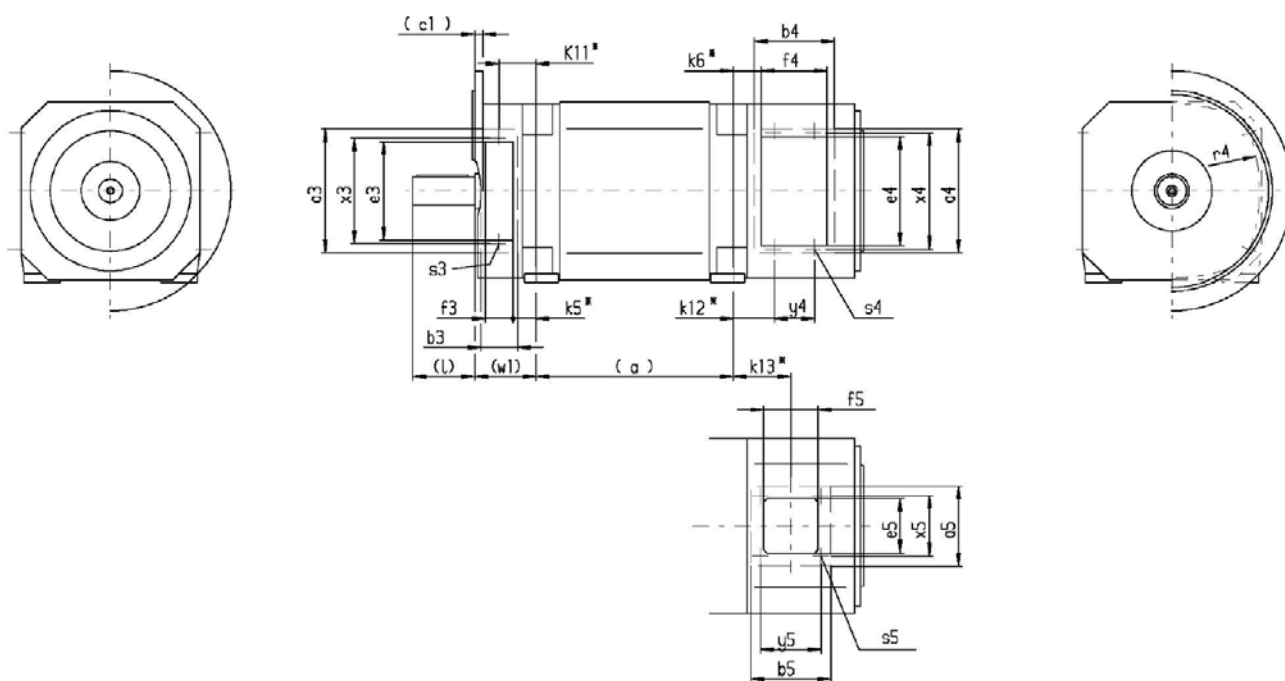

<b>DMR</b>	<b>a5</b>	<b>b5</b>	<b>e5</b>	<b>f5</b>	<b>k13*</b>	<b>s5</b>	<b>x5</b>	<b>y5</b>	
180	190	190	130	140	141	M8	144	151	
<b>DMR</b>	<b>a4</b>	<b>b4</b>	<b>e4</b>	<b>f4</b>	<b>k6*</b>	<b>k12*</b>	<b>s4</b>	<b>x4</b>	<b>y4</b>
180	280	170	248	150	55,5	75,5	4xM6	260	110
<b>DMR</b>	<b>a3</b>	<b>b3</b>	<b>e3</b>	<b>f3</b>	<b>k11*</b>	<b>k5*</b>	<b>s3</b>	<b>x3</b>	
180	265	70	235	58	70,5	42,5	2xM6	247	Feet
	215		184		68,5			198	Flange

## Dimensional drawings

### Filter

#### Rectangular filter

Dimensions with blower at top, with asterisk (\*) blower at side (in mm)

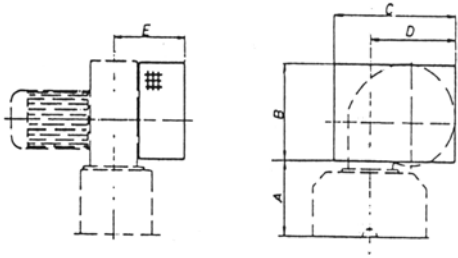

Filter to B side

View towards A side

Motor Size	Blower Type	A	A*	B	C	D	D*	E
112	BFB 398	130	150	176	246	157		145
132	BFB 635	158	178	236	336	235		189
160	BFB 752	190	206	276	386	271		280
180	BFB 752	210	215	276	386	271		280

#### Round filter

Dimensions with blower at top, with asterisk (\*) blower at side (in mm)

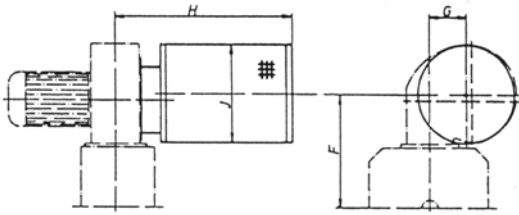

With sizes 112- 180 filter to A side

Motor Size	Blower Type	F	F*	G	G*	H	J
112	BFB 398	211	231	71		311	174
132	BFB 635	267	287	99		460	252
160	BFB 752	326	342	100		570	306
180	BFB 752	345	350	100		570	306

#### Sound absorber

Dimensions with blower at top, with asterisk (\*) blower at side (in mm)

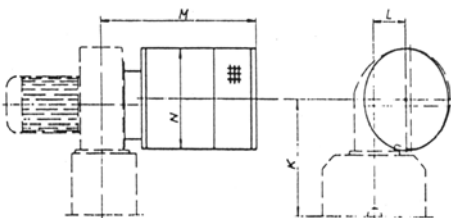

Motor Size	Blower Type	K	K*	L	L*	M	N
112	BFB 398	--	--	--	--	--	--
132	BFB 635	267	287	99		460	256
160	BFB 752	326	342	100		580	306
180	BFB 752	345	350	100		580	306

Up to size 180, sound absorber to A side

A sound absorber to the N side is possible; in this case, the sound absorber must be supported on the customer side.

In the case of sound absorbers at the side, support must be on the customer side.



### **Operation and Maintenance instructions**

For commissioning of the DMR motors, please request the corresponding Operating and Maintenance instructions.







**ABB Automation Technology Products AB**

DC Motors

S-721 70 Västerås

Sweden

Telephone: +46 21 32 90 00

Telefax: +46 21 32 95 15

[www.abb.com/motors&drives](http://www.abb.com/motors&drives)